

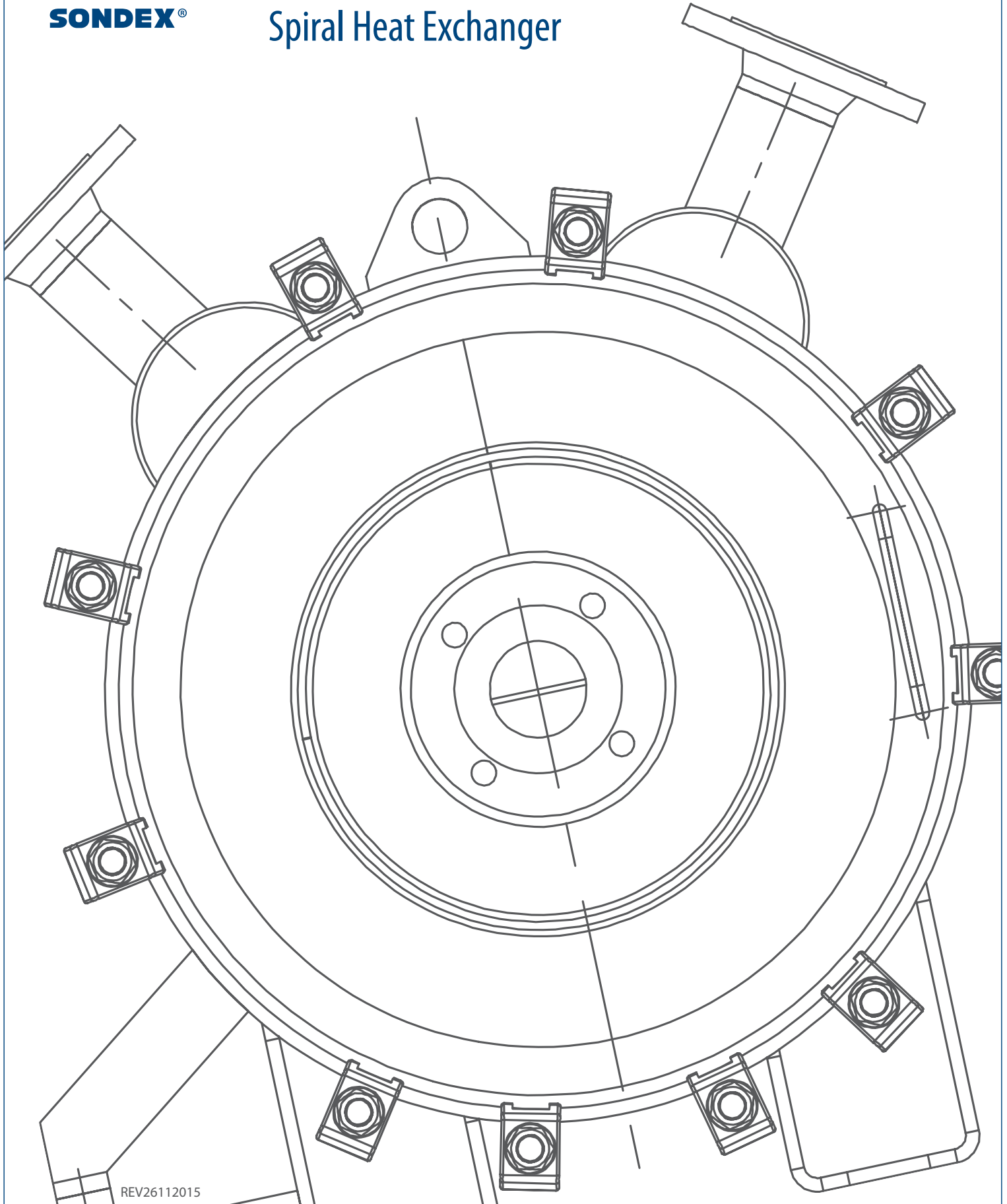

**SONDEX**®

# ▶ **Instruction and Maintenance Manual**

## Spiral Heat Exchanger



# 1. Content

Description.....	Section 2
Introduction.....	Section 3
Important safety Precautions.....	Section 4
Generally.....	Section 5
Correct Operation.....	Section 6
Safety Alert Notices.....	Section 7
Thermal Design.....	Section 8
Installation.....	Section 9
Maintenance.....	Section 10

## 2. Description

This instruction book is meant as a guide in connection with installation, operation and maintenance of Sondex spiral heat exchangers. A spiral heat exchanger utilizes the spiral flow on both sides of the heat exchanger. Spiral heat exchangers are typically used for liquids-liquids ratio, gas into liquids or condensing of steam into liquids.

## 3. Introduction

The instruction book can be used for all spiral heat exchangers produced and delivered by Sondex

Sondex cannot be held responsible for damages as a result of incorrect installation; use and/or maintenance of Sondex spiral heat exchanger, in case the instructions in this instruction book have not been observed.

Please notice that our spiral heat exchangers are specially designed and built for operation conditions (pressure, temperatures, capacities and liquid types), provided by the customer. Pressure peaks over normal working pressure or shock waves occurring by start/stop of the system may result in severe damages and must be avoided. Sondex cannot be held responsible for damages arisen as a result of any operation deviating from the original design conditions.

## 4. Important safety Precautions

Following points MUST be observed when working with spiral heat exchangers:

- Observance of local valid safety precautions.
- Before work is started make sure that the outlet of the spiral heat exchanger is free, emptied and cooled below 40°C.
- Always use gloves before handling the spiral heat exchanger in order to avoid hand injury from sharp edges.
- The Law or other regulations may require acquisition of suitable protection measures in the company



**YELLOW TRIANGLE:** Refers to applicable SAFETY ALERT notices in this instruction book. This information is given where danger of bodily harm is present.

## 5. Generally

### Identification of the Spiral heat exchanger

All types of Sondex spiral heat exchangers are supplied with a name plate with following specifications:

- Type of spiral heat exchanger
- Year of production
- Manufacturing number
- Nominal capacity in kW
- Effective heating surface in m<sup>2</sup>
- Max. working pressure in bar
- Test pressure in bar
- Max. working temperature in °C
- Max. differential pressure
- Volume
- Flow

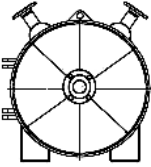
<b>SONDEX A/S</b>			
SHE Type:	<input type="text" value="1231"/>	Build Year:	<input type="text" value="123"/>
Serial Number:	<input type="text" value="test2spiral"/>	Marking:	<input type="text"/>
Nom. Capacity: [kW]	<input type="text" value="123"/>	Flow: [l/h]	<input type="text" value="123"/>
Heat Surface [m2]:	<input type="text" value="123"/>		
Max. Working Pressure: [Bar]	Product / Medium <input type="text" value="12 / 12"/>		
Max Differential pressure: [Bar]	<input type="text" value="12"/>		
Volume Product side [ltr]	<input type="text" value="12"/>	Volume Medium side [ltr]	<input type="text" value="12"/>
Min. Working Temp.: [C]	<input type="text" value="12"/>	Max Working Temp.: [C]	<input type="text" value="12"/>
			
<b>IMPORTANT:</b>			
1) The starting of the phe must be done without shocks and against closed valves.			
2) Max. working pressure and temperature may not be exceeded at any time.			
SONDEX A/S - DK-6000 - KOLDING - DENMARK			

## 6. Correct Operation

This user manual provides information and instructions for correct and safe operation of the unit. Many accidents are caused by incorrect use! It is essential that you study the instructions carefully, and above all, ensure the availability to those who install, maintain and operate the spiral heat exchanger on a daily basis. This manual is of no value if it is not available at the time when your staff needs it.

If a problem occurs with your Sondex Spiral Heat Exchanger which is beyond the scope of this manual, do not hesitate to contact us. The installation should not be put into operation before all indistinctnesses have been solved!

To avoid injuries and damages, follow the instructions and local applicable safety regulations. Also take the necessary protective measures, depending on the nature of your process or circumstances related to it, at your plant.

We draw your attention to the fact that our spiral heat exchangers are specially built and designed according to the requirements of the customers (pressure, temperature, capacity liquid types). Sudden abnormal pressure shock and pressure above working pressure at start-up/stop may result in severe damages and should be avoided. Furthermore, pressure shock from e.g. positive-pumps result in damages on the spiral heat exchanger. Sondex cannot be held responsible for damages arisen in consequence of wrong operation. In case of amendments of the operation conditions please contact Sondex.

## 7. Safety Alert Notices

### **Bodily harm can be caused by:**

- Burning as a result of touching the spiral heat exchanger or other parts of the installation;
- The uncontrolled release of pressurized media with which the danger of burning and other injuries is present;
- Contact with chemicals;
- Touching sharp edges of the installation.

### **Damage to equipment can be caused by:**

- External forces;
- Corrosion;
- Chemical action;
- Erosion;
- Material fatigue;
- Water hammer;
- Thermal and/or mechanical shock
- Freezing;
- Wrong transport/lifting.

Be careful by stop of the plant, as some parts may still be hot. The spiral heat exchanger is only applicable with the media stated in the data list. For the prevention of damages the cold and hot media must run through the spiral exchanger simultaneously. In case the cold medium is not adrift simultaneously with the hot medium, the cold medium may start boiling depending on pressure and temperature/pressure and media types, and the spiral heat exchanger may be damaged. Sudden pressure and temperature amendments should be avoided.

When a spiral heat exchanger (filled with water or liquid compounds) is not in operation and is subject to temperatures below 0°C a deformaty risk is present in case of icing. In case of frost risk the spiral heat exchanger must be totally emptied.

Leak risks are always available. Therefore we advise you to take this into account by installation and we

recommend a drip tray under the spiral heat exchanger in order to avoid liquid on the floor and/or damages on associated electronic equipment (short circuit, moisture damage).

If the spiral heat exchanger is used at temperatures above 60°C/or with aggressive liquids, it is recommended to shield the spiral heat exchanger so that the risk of contact is avoided. In case of welding work near the spiral heat exchanger this must never be used as earth connection for the construction work. Voltage may result in severe damages to the spiral heat exchanger. Therefore demount the connection flanges and thereafter isolate the spiral heat exchanger from the system.

## 8. Thermal Design

The construction and calculation of Sondex spiral heat exchangers are based on the newest technology. Performance tests must always take place in a totally cleaned spiral heat exchanger. The nominal performances/pressure loss are stated in the Sondex data lists.

Especially with regard to the pressure loss a minor rise up to 15% must be expected on the side with the lowest working pressure. This depends on specifications and the difference between the two working pressures.

## 9. Installation

### Requirements to the installation area:

It is very important that enough space around the spiral heat exchanger is kept free for servicing of the unit

### Installing the pipe connections

The Sondex spiral heat exchanger will be provided with flanges, connections, threaded pipes, etc.



### WARNING

When connecting the pipe system to the spiral heat exchanger make sure that no stress or strain is imposed, by the pipe system, onto the spiral heat exchanger!

### We advise you of the following:

- Heavy pipe work needs to be supported. This will prevent heavy forces on the spiral heat exchanger.
- Always install flexible connections on the spiral heat exchanger to prevent vibrations. These flexible connections also prevent expansion of the pipe work, caused by temperature influence, onto the spiral heat exchanger.
- The pipe work needs to be thoroughly cleaned and flushed before connecting to the spiral heat exchanger.
- Always install vents on both sides of the spiral heat exchanger.

### Valve direction and pumps:

Avoid that the nominal pressure of the equipment is exceeded and take necessary precautions in order to avoid pressure chocks (water hammer). To isolate the unit it is of big importance that the connection pipes are supplied with valves.

All valves must be opened slowly in order to increase the flow velocity successively at start-up. The flow velocity is reduced successively during stop. In order to secure a normal flow during maintenance bypass lines are recommended.

When using displacement pumps a decompression bypass line with a time controlled, slowly-working valve is recommended. Furthermore, take precautions by means of pressure controlled switches, pressure relief gauges, delivery pipes when using pumps with adjustable velocities and shut-off pumps.

Large tolerances, especially pressure drop increases beyond the nominal values stated, must be considered when calculating associated products, such as pumps and spiral heat exchangers. These are results of possible variations of the liquid-properties, the flow velocities, boiler scale or deposits on the heat transmission surfaces.

### Assembling

Lift the spiral heat exchanger by means of the lifting eyes only!  
Install any drain/pet valves.

ALWAYS: Use the lifting eyes (if fitted)

NEVER: Lift using the connections



### WARNING

Never lift the spiral heat exchanger by means of connections or studs.

## 10. Maintenance

### 10.1. Preparation

Repairs must be undertaken by skilled manpower employed by Sondex and with knowledge of spiral heat exchangers. Inspection of the units must take place according to the regulations valid in the country where the unit is installed.

### 10.2. Fouling and Clogging

The construction with only one single channel makes fouling velocity slow, but various kinds of deposit on the surfaces of the walls may occur. The deposits consist of materials with a low thermal conductivity which will increase the total resistance of the wall. In consequence of this a layer of deposits may reduce the total heat transfer velocity heavily and corrosion may appear in cracks below these deposits.

Sondex recommend all repairs to be undertaken by skilled manpower with a thorough knowledge of spiral heat exchangers.

### 10.3 Cleaning

In order to maintain the nominal performances the heat transfer surfaces must be kept clean. Cleaning in place (CIP) without opening the spiral heat exchanger or manual cleaning after opening the spiral heat exchanger (see below) is possible.

### 10.4 Cleaning In Place (CIP)

The most effective procedure is to rinse the spiral heat exchanger frequently without opening the doors and to use of a suitable solvent, acid or alkaline solution.

The pipes must be supplied with by-pass valves enabling circulation of the detergents. In order to obtain the best results the flow direction must be opposite the normal flow direction (Backflush). The detergents must be compatible with the installation and used according to instructions of Sondex. Never use solutions with chlorides. Make sure that the detergent is suitable for the gasket.

The flow velocity for the detergent solution must be equal to or larger than the nominal flow velocity. However, flow velocities significantly lower than the nominal flow velocity, can have an acceptable effect, when compensating with a prolonged cleaning.

After cleaning the spiral heat exchanger must be thoroughly rinsed with water in order to remove any detergent surplus, especially when acids have been applied. Check pH and chloride content in the rinse water. The spiral heat exchanger must be totally emptied unless it is set adrift again.

The type of solution and the cleaning frequency must be fixed in every single case. Below follows general directives.

Type of Deposit	Scale Cleaning Detergent	Limitation
Grease, wax	Hot water or steam petroleum	
Grease, proteins	Sodium hydrate	Max. 15% and 60°C
Fouling of biological growth	Sodium hydrate Sodium carbonate	Max. 15% and 60°C Max. 15% and 60°C
Calcium Carbonate Calcium Sulphate Silicates, sulphide	Nitric acid Sulphuric acid	Max. 15% and 60°C Max. 3% and 20°C
Metallic oxides Aluminium oxide Corrosives	Phosphoric acid Sulfamic acid Citric acid  All acids are only intended for stainless steel Complex agents (EDTA) Sodium polyphosphate	Max. 20% and 60°C Max. 5% and 50°C Max. 20% and 60°C
Residual oil, asphalt Hydrocarbon deposits	Paraffin or naphta based solvents	



### WARNING

Only apply Inhibited hydrochloric acid on carbon steel. All other acids are only suitable for stainless steel. Max. 250 ppm chlorides in all acids, demineralized water and rinsing water applied for stainless steel at max. temperatures of 60°C.

Protect carbon steel parts when corroding chemicals are applied.

If CIP (Cleaning In Place) is not possible, the cover is removed and the unit is cleaned mechanically or manually. Remove loose depots of fixed substances manually. A high-speed water or steam jet is recommended for effective removal of fixed substances and deposits.

### 10.5 Re-Rinsing

In case of clogging because of deposits of fixed substances at the inlet or in the first part of the channel, re-rinsing may be a good solution. Re-rinsing is turning the flow direction of the one or both liquids or rinsing with water in the opposite direction of the normal flow direction. The flow should be bigger than the normal flow in a period of 15-30 minutes.



*Specially designed with built-in flushing connections*



*Long-life gasket solution*



## WARNING!

**By inspection of a passage do not open the spiral heat exchanger before the pressure is totally shut off on both sides of the installation!**

If it is the intent to inspect the one side of the spiral heat exchanger with the other side still under pressure, the removed cover must be replaced by a special device approved by Sondex in order to avoid damages on the spiral body. Please contact Sondex for further information.

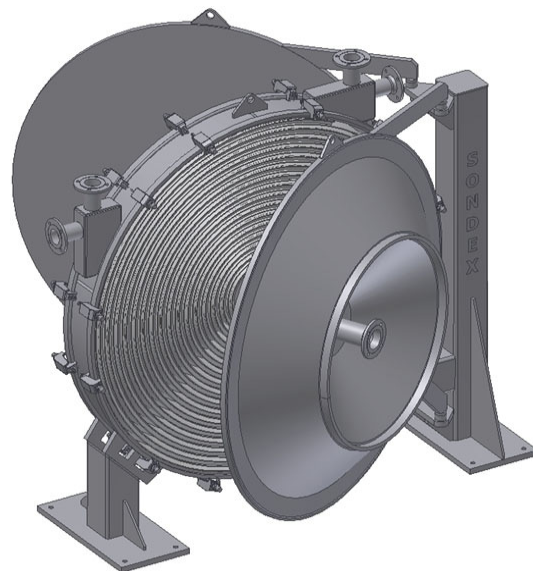

### 10.6 Opening of the Unit

1. Close the main valves of the in-/outlet side and let the spiral heat exchanger cool before opening.

Control that:

- None of the sides of the spiral heat exchangers are under pressure
- Both sides of the spiral heat exchanger are emptied.

2. Disconnect the pipes

3. Most of the spiral heat exchangers are equipped with flat (or conical strengthened) covers which are kept down by means of suitable tools.

The contact gaskets can stick to the surfaces of the covers or the surfaces of the body. When the remaining gasket material is removed, avoid damaging the surface of the covers the edges of the spiral heat exchanger body plate or the sealing ring.



### 10.7 Maintenance

Each channel can be examined visually from one of the sides of the spiral heat exchanger body. If the spiral heat exchanger has a big channel width and/or a small distance it may be necessary to use an endoscope.

The channels must be examined for:

- Corrosion - often visible at the sealed weldings near the surface of the body and thus easy to find
- Erosion - often visible in the middle or peripheral inlet and near the distance plates
- Fouling/clogging. In spiral heat exchangers deposits of fixed substances in the bottom part.
- Mechanical damage (deformation).

In case of heavy corrosion, erosion or a mechanical damage, contact Sondex for advice with regard to possible repair in place.

### 10.8 Reassembling

During reassembling of the Spiral Heat Exchanger the gasket must be renewed. Even if the gasket appears to look normal, the necessary compression properties are no longer available in the gasket due to the high compression under service. Make sure that the contact gaskets are intact and clean before reassembling. By replacement of gaskets please contact Sondex.



**The gasket must be replaced after opening of the Spiral Heat Exchanger!**

The spiral heat exchanger is supplied with a specific number of hook bolts and the spiral heat exchanger may not be operated with a less number or other dimensions of hook bolts. The distance between the hook bolts has to be the same distance as between the hook bolts on the cover.

### Tightening Torque

Head/follower and the gasket are replaced when reassembling. Gradually fasten the fang bolts diagonally to the lowest tightening torque. In order to secure that the unit is tight it is possible to increase the tightening torque, however, without exceeding the maximum value stated in below table.

Hook Bolt Type	Gasket Type	Min. Torque (N.M)	Max. Torque (N.M)
	NBR/EPDM	150	450

## 10.9 Test

### Hydraulic test

It is possible to use normal hydraulic test procedures after total reassembling of the spiral heat exchanger.

#### Air under water test

- Supply air at low pressure (0.2-0.5 bar overpressure) in the closed channel.  
Do not exceed 0.5 bar overpressure.
- Air bubbles will reveal any leaks in the channel welding.
- Repeat the procedure for the other channel welding, if necessary.
- A normal hydraulic test can be undertaken after a total reassembling of both covers. The maximum test pressure is stated on the name plate.

A hydraulic test must always be made before test by means of air or other compressed gases and may involve special national safety rules which must be observed. To reveal leaks by means of gas or air it is sufficient to use a very low pressure (overpressure 0.5 bar) it is also possible to use a less volatile gas (e.g. helium) instead of putting the whole system under pressure.



#### **WARNING:**

It is of utmost importance to fix the side to be tested by means of cross balks. Otherwise the hydraulic pressure may deform the body and thus result in permanent or irreparable damages.

Test by means of air or other compressed gases must be in accordance with any national security and regulations.



**SONDEX®**

#### **Sondex Head Office**

Marsvej 5  
DK - 6000 Kolding  
Denmark  
Tel. +45 76 306 100  
Fax (1) +45 75 538 968  
Fax (2) +45 75 505 019  
info@sondex.dk  
www.sondex.dk