



**KOLMEKS**

INLINE SD-PUMPS  
WITH IEC-STANDARD MOTOR







**KOLMEKS**  
TEHOKASTA LUOTETTAVUUTTA



INLINE SD- PUMPS  
WITH IEC-STANDARD MOTOR  
L\_-ja AL\_-series, flanged DN100 - DN250

## General technical data

### Inline SD- pumps with IEC- standard motor L\_ and AL\_- series pumps

- Inline centrifugal pumps equipped with flange connections.
- Pumps can be used as circulation, pressure boosting and transfer pumps for clean liquids.

### Applications:

- Grey cast iron (L- and AL) pumps can be used as circulation, pressure boosting and transfer pumps for clean liquids.
- Nodular cast iron (LH and ALH) pumps can be used in power plants and as pressure boosting pumps for primary district heating.
- Bronze (LP and ALP) pumps can be used as domestic hot water, circulation, pressure boosting and transfer pumps for clean oxygen-rich and some slightly aggressive liquids.
- Stainless steel AISI316 (LS and ALS) pumps can be used as circulation, pressure boosting and transfer pumps for acid and alkaline liquids.

**Note!** The suitability of materials and seals for the liquid to be pumped must always be confirmed when selecting a pump.

## Quick Selection Chart for SD-pumps with IEC- standard motor, L- and AL-series, 50Hz

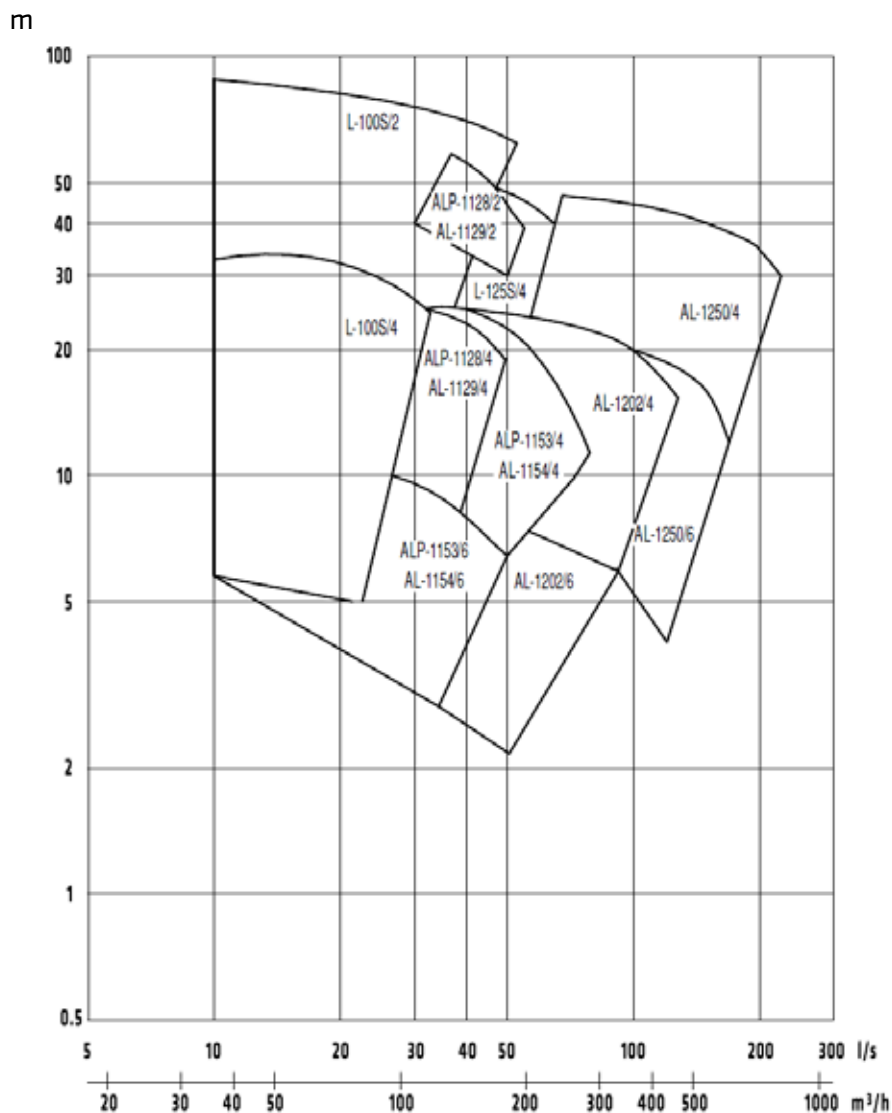

## Quick Selection Chart for SD-pumps with IEC- standard motor, L- and AL-series, 60Hz

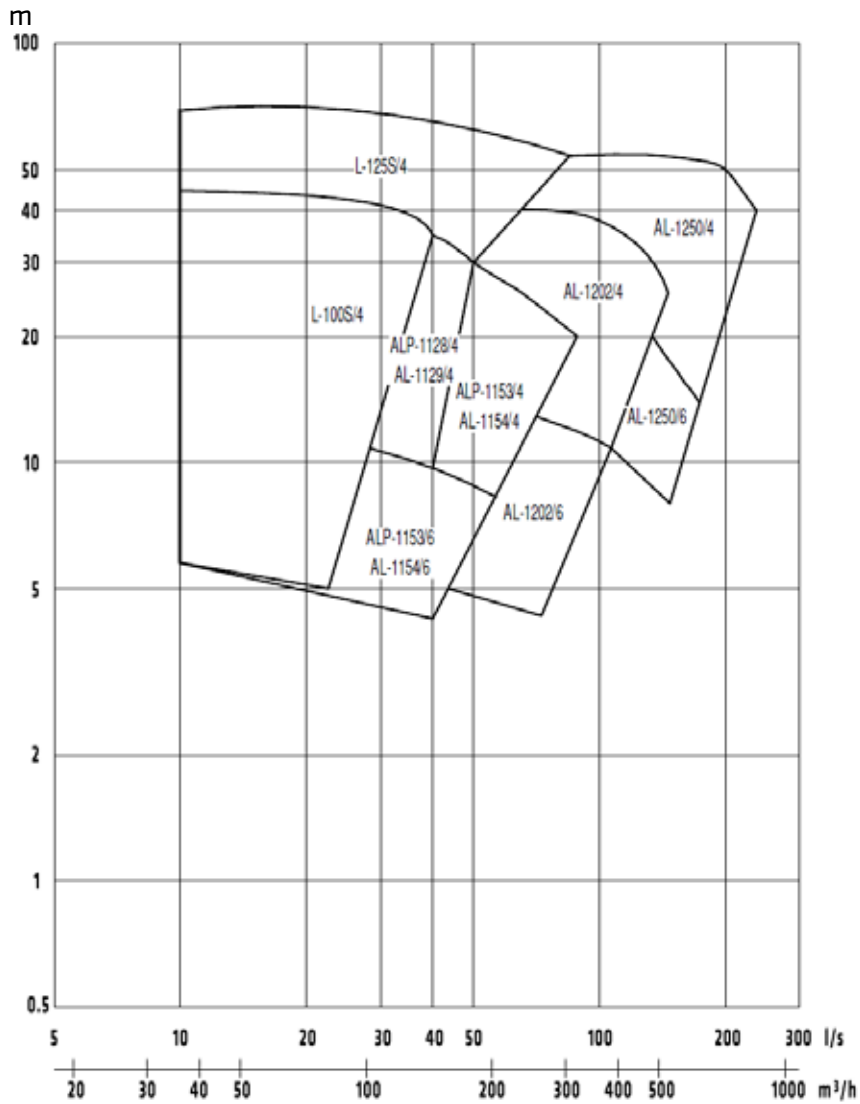

Standard materials and fields of application for SD-pumps L\_ and -AL\_-series

| Connection | Grey cast Iron<br>EN-GJL-200, PN10 | Nodular cast iron<br>EN-GJS-400, PN16 | Bronze<br>CuSn10Zn2, PN10 | Stainless steel<br>AISI 316, PN 16 | Stainless steel<br>SS 2378-254<br>SMO | Shaft seal, PN10<br>Ø [mm], materials | O-ring<br>size [mm] | O-ring<br>material | Motor<br>[kW] |
|------------|------------------------------------|---------------------------------------|---------------------------|------------------------------------|---------------------------------------|---------------------------------------|---------------------|--------------------|---------------|
| DN 100     | L-100S/4 SD                        | LH-100S/4 SD                          | LP-100S/4 SD              | -                                  | -                                     | 32, carbon/SiC EPDM                   | 315 x 6,3           | EPDM               | 3-22          |
|            | L-100S/2 SD                        | LH-100S/2 SD                          | LP-100S/2 SD              | -                                  | -                                     | 32, carbon/SiC EPDM                   | 315 x 6,3           | EPDM               | 15-37         |
|            | L-100S/2 SD                        | LH-100S/2 SD                          | LP-100S/2 SD              | -                                  | -                                     | 40, carbon/SiC EPDM                   | 315 x 6,3           | EPDM               | 45            |
| DN 125     | AL-1129/4 SD                       | ALH-1129/4 SD                         | -                         | ALS-1129/4 SD                      | ALM-1129/4 SD                         | 32, carbon/SiC EPDM                   | 309/295X1           | gasket             | 3-22          |
|            | AL-1129/2 SD                       | ALH-1129/2 SD                         | -                         | ALS-1129/2 SD                      | ALM-1129/2 SD                         | 32, carbon/SiC EPDM                   | 309/295X1           | gasket             | 30-37         |
|            | -                                  | -                                     | ALP-1128/4 SD             | -                                  | -                                     | 32, carbon/SiC EPDM                   | 309/295X1           | gasket             | 3-22          |
|            | -                                  | -                                     | ALP-1128/2 SD             | -                                  | -                                     | 32, carbon/SiC EPDM                   | 309/295X1           | gasket             | 30-37         |
|            | L-125S/4 SD                        | LH-125S/4 SD                          | -                         | LS-125S/4 SD                       | -                                     | 40, carbon/SiC EPDM                   | 405 X 7             | EPDM               | 18,5-37       |
|            | L-125S/4 SD                        | LH-125S/4 SD                          | -                         | LS-125S/4 SD                       | -                                     | 50, carbon/SiC EPDM                   | 405 X 7             | EPDM               | 45-55         |
| DN 150     | -                                  | -                                     | ALP-1153/6 SD             | -                                  | -                                     | 32, carbon/SiC EPDM                   | 309/295X1           | gasket             | 5,5-11        |
|            | -                                  | -                                     | ALP-1153/4 SD             | -                                  | -                                     | 32, carbon/SiC EPDM                   | 309/295X1           | gasket             | 4-30          |
|            | AL-1154/6 SD                       | ALH-1154/6 SD                         | -                         | ALS-1154/6 SD                      | ALM-1154/6 SD                         | 32, carbon/SiC EPDM                   | 309/295X1           | gasket             | 5,5-11        |
|            | AL-1154/4 SD                       | ALH-1154/4 SD                         | -                         | ALS-1154/4 SD                      | ALM-1154/4 SD                         | 32, carbon/SiC EPDM                   | 309/295X1           | gasket             | 4-30          |
| DN 200     | AL-1202/6 SD                       | ALH-1202/6 SD                         | ALP-1202/6 SD             | ALS-1202/6 SD                      | ALM-1202/6 SD                         | 32, carbon/SiC EPDM                   | 315 x 6,3           | EPDM               | 4-11          |
|            | AL-1202/6 SD                       | ALH-1202/6 SD                         | ALP-1202/6 SD             | ALS-1202/6 SD                      | ALM-1202/6 SD                         | 40, carbon/SiC EPDM                   | 315 x 6,3           | EPDM               | 15-18,5       |
|            | AL-1202/4 SD                       | ALH-1202/4 SD                         | ALP-1202/4 SD             | ALS-1202/4 SD                      | ALM-1202/4 SD                         | 32, carbon/SiC EPDM                   | 315 x 6,3           | EPDM               | 15-18,5       |
|            | AL-1202/4 SD                       | ALH-1202/4 SD                         | ALP-1202/4 SD             | ALS-1202/4 SD                      | ALM-1202/4 SD                         | 40, carbon/SiC EPDM                   | 315 x 6,3           | EPDM               | 22-37         |
|            | AL-1202/4 SD                       | ALH-1202/4 SD                         | ALP-1202/4 SD             | ALS-1202/4 SD                      | ALM-1202/4 SD                         | 50, carbon/SiC EPDM                   | 315 x 6,3           | EPDM               | 45            |
| DN 250     | AL-1250/6 SD                       | ALH-1250/6 SD                         | -                         | ALS-1250/6 SD                      | -                                     | 40, carbon/SiC EPDM                   | 405 X 7             | EPDM               | 15-22         |
|            | AL-1250/6 SD                       | ALH-1250/6 SD                         | -                         | ALS-1250/6 SD                      | -                                     | 50, carbon/SiC EPDM                   | 405 X 7             | EPDM               | 30            |
|            | AL-1250/4 SD                       | ALH-1250/4 SD                         | -                         | ALS-1250/4 SD                      | -                                     | 40, carbon/SiC EPDM                   | 405 X 7             | EPDM               | 37            |
|            | AL-1250/4 SD                       | ALH-1250/4 SD                         | -                         | ALS-1250/4 SD                      | -                                     | 50, carbon/SiC EPDM                   | 405 X 7             | EPDM               | 45-55         |
|            | AL-1250/4 SD                       | ALH-1250/4 SD                         | -                         | ALS-1250/4 SD                      | -                                     | 65, carbon/SiC EPDM                   | 405 X 7             | EPDM               | 75-90         |

| SERIES   | Pressure class / temperature [°C]                  | Housing material Name | Marking    | Sealing flange | Impeller   | Pump shaft | Difference in materials  |
|----------|--|-----------------------|------------|----------------|------------|------------|--|
| L / AL   | PN10 / -15...+120                                  | grey cast iron        | EN-GJL-200 | EN-GJL-200     | EN-GJL-200 | AISI329    | Bronze impeller available to all pumps<br><br>On special request also SS2324 (AISI 329) ja SS2378 "SMO" (LM / ALM-pumps) |
| LH / ALH | PN16 / -15...+180 (depending on seal construction) | nodular cast iron     | EN-GJS-400 | EN-GJS-400     | EN-GJL-200 | AISI329    |  |
| LP / ALP | PN10 / -15...+120                                  | bronze                | CuSn10Zn2  | CuSn10Zn2      | CuSn10Zn2  | AISI329    |  |
| LS / ALS | PN16 / -15...+180 (depending on seal construction) | stainless steel       | AISI316    | AISI316        | AISI316    | AISI329    |  |

Standard shaft material is Stainless steel AISI 329. In LM / ALM-pumps shaft material is Stainless steel SMO, SS2378.

## Structure

### SD-pump

L- and AL-series pumps are monoblock centrifugal pumps equipped with IEC- standard motor

### IEC- standard electric motor

The electric motor of L and AL series SD- pump is a IEC- standard asynchronous motor designed specifically for pump use. The electric motor is highly efficient and has low noise levels. The electric motor is suitable for frequency converter use.

Standard voltages: 690/400 V, 50 Hz 4-90 kW

660/380 V, 60 Hz 4-90 kW

690/400 V, 60 Hz 4-90 kW

440 V, 60 Hz 4-105 kW

460 V, 60 Hz 4-110 kW

480 V, 60 Hz 4-110 kW

Note! In the data sheets, value of the nominal currents are indicated as approximate values for 400 V, 50 Hz ja 380-480 V, 60 Hz.

The exact values depend on the motor type, efficiency class and brand of motor. That exact values are informed in the order confirmation and motors rating plate.

Enclosure class: IP55

Insulation class: F

Duty type: S1 (continuous duty)

Ambient temperature: max. +40°C

**NOTE!** The IEC- standard electric motors are available in other enclosure classes and voltages by request.

### Connections

The L- and AL-series pumps are equipped with flanged connections (PN10 or PN16) according to ISO 7005.

Flanges to ANSI/JIS standards are available by request.

### Seals

The standard shaft seal on L- and AL-series pumps is a single mechanical seal. The pump housing seal is an O-ring or flat gasket.

By request, there are several seal materials and structure alternatives available depending on the properties and temperature of the liquid.

### Standard surface treatment

All parts of the pumps and motor brackets are painted according to Standard SFS-EN ISO 12944-5, AY80/2 FcSa2. The color is RAL3020.

The IEC standard motors are painted according to the motor manufacturers standards with their original standard paint and colour. The exact paints and colours depend on the motor supplier and the brand of the motor.

### Special surface painting

Epoxy surface treatment and colour alternatives are available by request.



Type markings  
Rating plate for pump

**Material:**  
P = Bronze  
H = Nodular Cast Iron  
S = Stainless steel AISI316

**Flange DN-size**

**Pole number of motor:**  
2: 3000r/min 50Hz  
3600r/min 60Hz  
4: 1500r/min 50Hz  
1800r/min 60Hz  
6: 1000r/min 50Hz  
1200r/min 60Hz

**Accessories:**  
T = External shaft seal  
H = Internal or external flushing  
KT = Double shaft seal  
Sn = Non-standard shaft seal  
Kn = Non-standard surface treatment

|  |                                 |                      |
|--|---------------------------------|----------------------|
| Type of pump                                 | <b>Pump ALH-1202/4H SD</b>      | <b>1403</b>          |
| Manufacturing number and -year               | <b>No 123456.10 2014 PN16</b>   | <b>Ø 315 mm</b>      |
| Duty point and max temperature of the liquid | <b>100 l/s 25 m +150 °C P2N</b> | <b>37 kW</b>         |
| Minimum efficiency index (MEI)               | <b>MEI ≥ 0,1 --</b>             | <b>400 V / 50 Hz</b> |

Manufacturing year and month  
Pressure class and impeller diameter and non-standard material of impeller:  
PM = Bronze  
SS = Stainless steel AISI316  
Nominal power of motor  
Nominal principal voltage of electrical network/frequency

Rating plate for motor

|   |  |    |                  |       |      |        |                |
|---|--|----|------------------|-------|------|--------|----------------|
|   | IE2  |    |                  |       |      |        |                |
| Motor type                              | 3~ motor M3AA 225 SMA 4  |    |                  |       |      |        | 2014           |
|   | No.  |    |                  |       |      |        | Ins.cl F IP 55 |
| Nominal voltages frequencies and powers | V  | Hz | kW               | r/min | A    | cos φ  | Duty           |
|   | 400 D  | 50 | 37               | 1479  | 68,0 | 0,84   | S1             |
|   | 690 Y  | 50 | 37               | 1479  | 39,4 | 0,84   | S1             |
|   | 415 D  | 60 | 37               | 1481  | 68,0 | 0,81   | S1             |
|   | 460 D  | 60 | 37               | 1782  | 59,0 | 0,84   | S1             |
| Efficiency class of electric motor      | 50Hz: IE2 - 93.4(100%) - 93.8(75%) - 93.1(50%)<br>60Hz: IE2 - 93.6(100%) - 93.5(75%) - 92.5(50%) |    |                  |       |      |        |                |
| Bearing types                           | D.E. 6313-2Z/C3  |    | N.D.E 6212-2Z/C3 |       |      | 240 kg |                |
|   | IEC 60034-1  |    |                  |       |      |        |                |

Year of manufacture  
Insulation- and enclosure class  
Rotation speed, nominal currents, cos φ  
Continuous duty  
Weight of motor



## Seal structure alternatives

### Standard structure

- Single mechanical seal
- Max. operating temperature +120 °C.

The standard-construction shaft seal can also be used for water-glycol mixtures and most other indirect refrigeration systems. The recommended glycol is propylene glycol with a concentration of up to 50%. Most often, a concentration of 30–40% is adequate.

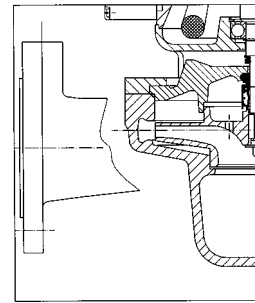

### Internal flushing

- Single mechanical seal
- Recirculation from the discharge flange of the pump to the seal chamber which flushes the seal
- Max. +150 °C water
- Available for flange sizes DN50 ... DN300. . This is indicated with an additional marking 'H' in the pump type e.g. LS-125S/4 SD H.

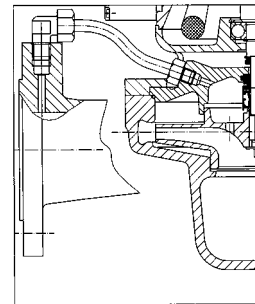

### External flushing

- Single mechanical seal
  - A pipe from an external source plugged to the seal chamber which makes it possible to flush the seal with external pressure if required
  - Available for pumps in flange sizes DN 50–300
  - Crystallising and accumulative liquids
- This is indicated with an additional marking 'H' in the pump type e.g. LS-125S/4 SD H.

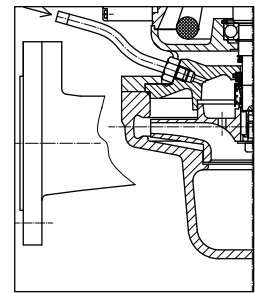

### External seal

- Externally-mounted single mechanical Teflon bellows
- Available for flange sizes DN 65–300 ALS pumps
- Extremely corrosive liquids, e.g. sulfuric acid
- Marking 'T' in the pump type e.g. ALS-1106/4 SD T
- NOTE! Maximum working pressure 10 bar

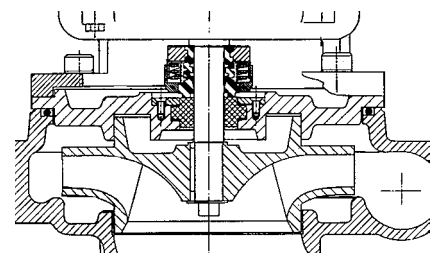

### Double mechanical seal system (cartridge)

- Two opposing seals with sealing liquid brought from outside (circulation). The pressure of the liquid can be lower or higher than that of the liquid being pumped
- Available for flange sizes DN 65–300 pumps
- Max. operating temperature +180°C for water
- Requires a separate seal water monitoring unit (available from Kolmeks)
- Marking 'KT' in the pump type e.g. ALS-1154/4 SD KT
- Hot, crystallizing and accumulative liquids

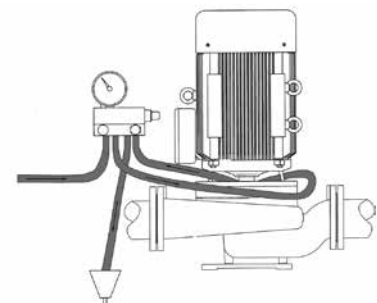

## Installation

Ensure the following when installing the pump:

- Enough room for service and inspection
- Possibility to use lifting and transfer devices if required
- Shut-off valves on both sides of the pump, allowing the position of the motor unit and the electrical terminal connection box to be changed by removing the motor unit from the pump housing and by installing it in the required position (not applicable when using internal seal flushing, marking 'H' which is standard in the LH/ALH series)

Kolmeks Inline SD-pumps are installed always on a base plate and vertical position.

When selecting a method of installation, please consider at least the following:

- Enough room for installation and service
- Strength, rigidity and support of the piping
- Vibration and noise level requirements

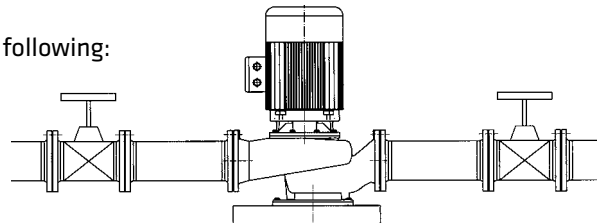

Kolmeks Inline SD- pumps are always fastened by their base plate onto a freely moving concrete plinth, which is separated from the floor by a 20-mm thick rubber or cork mat for example. The weight of the concrete base must be about 1.5 times the weight of the pump.

## Spare parts and service for SD-pumps

### Parts list

- |           |                                |
|-----------|--------------------------------|
| <b>1</b>  | Electric motor                 |
| <b>2</b>  | Pump housing                   |
| <b>3</b>  | Impeller                       |
| <b>5</b>  | Sealing flange                 |
| <b>8</b>  | Base plate                     |
| <b>14</b> | Coupling                       |
| <b>21</b> | Flange-shaft                   |
| <b>22</b> | Screw                          |
| <b>24</b> | Screw                          |
| <b>25</b> | Washer                         |
| <b>40</b> | Mechanical shaft seal          |
| <b>50</b> | O-ring or gasket               |
| <b>60</b> | Screw / Nut                    |
| <b>62</b> | Screw                          |
| <b>67</b> | Screw                          |
| <b>70</b> | Screw / Nut                    |
| <b>73</b> | Screw                          |
| <b>80</b> | Pipe joint (ALH- ja LH-series) |
| <b>81</b> | Pipe joint (ALH- ja LH-series) |
| <b>86</b> | Pipe (ALH- ja LH-series)       |
| <b>89</b> | Washer                         |
| <b>92</b> | Coupling protection            |

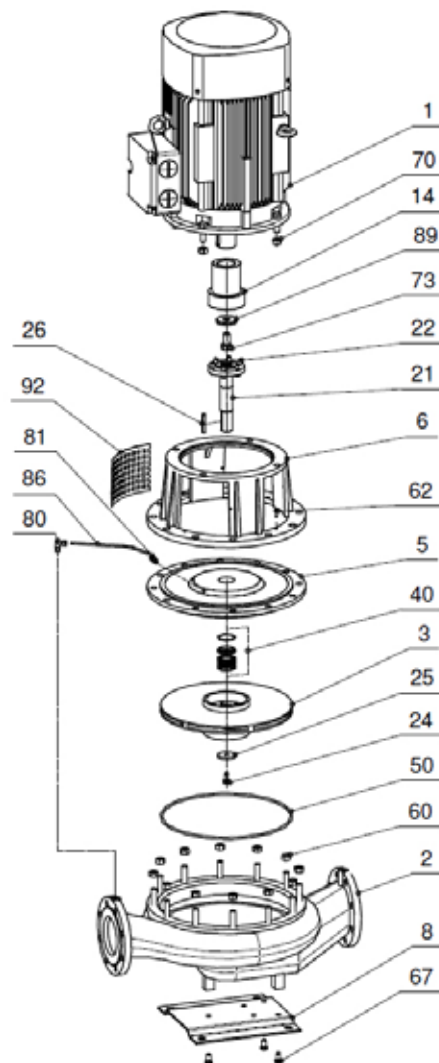

## Drive unit

The drive unit is a new stand-by operation unit which includes:

- 1) Motor
- 2) Sealing flange
- 3) Impeller
- 4) Seals

If a motor malfunction or a seal leak occurs, replacing the motor unit is simple and quick and does not require long periods of stoppage. No procedures need to be carried out on the piping, because there is no need to detach the pump housing

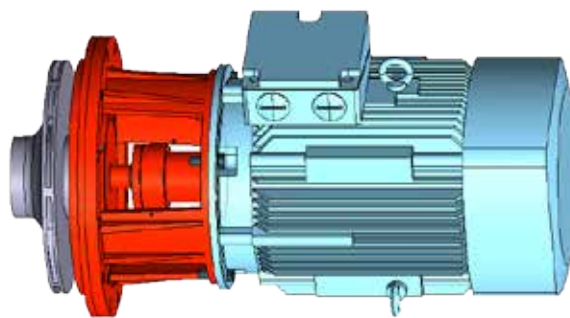

## Shaft seal

If a seal leak occurs in a new pump, e.g. during commissioning, it is possible to replace only the shaft seal with a new one.

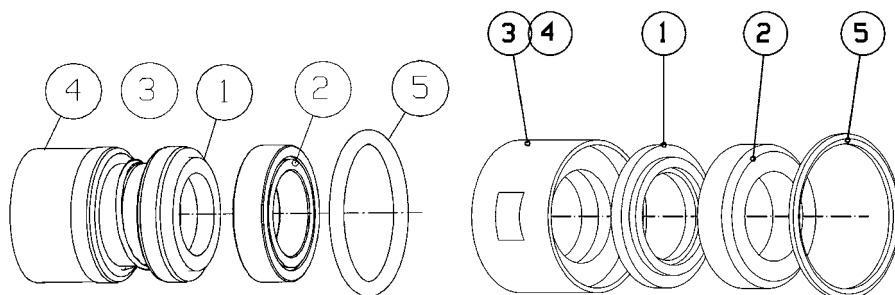

Parts of single mechanical shaft seal

- |   |                 |
|---|-----------------|
| 1 | Rotating ring   |
| 2 | Stationary ring |
| 3 | Body/bellows    |
| 4 | Spring          |
| 5 | O-ring          |

# Reading curves and selecting a pump

## AL\_-1250/4 SD DN250

Selecting a fixed speed pump from 50 Hz pump curve (curves on the left)  
 E.g. duty point: flow = 160 l/s, head = 35 m, liquid: water +20°C.

1. Use the quick selection chart at the beginning of the catalogue or browse through the product catalogue in order to find a pump of the correct size range such that the required flow 160 l/s is at the best efficiency point ( $\eta = 80\%$ ).

2. Select the impeller size [ $\varnothing = \text{mm}$ ] from the QH curve by drawing a vertical line through the point of 160 l/s flow and, equivalently, a horizontal line through the point of 35m head.

3. Find the impeller size at the intersection = 380 mm. Note! If the intersection falls between two impeller sizes, the impeller diameter is selected halfway between the two sizes.

4. Read the nominal shaft power of the motor from the section in which the QH curve is.  
 In this example, the motor nominal shaft power is  $P_2N = 75 \text{ kW}$ .  
 According to the shaft power  $P_2$ ,  $P_2 = 71 \text{ kW}$ , the motor nominal power becomes  $P_2N = 75 \text{ kW}$  (the closest highest motor nominal power).

5. Check the nominal current of the electric motor from the column on the right-hand side of the nominal power column in the table,  $IN = 133.9 \text{ A}$ . Select an overload protection for the motor according to nominal current.

6. Read the pump weight from the same table [ $\text{kg}$ ] = 900 kg.

7. For energy calculation, read the electrical power of the device =  $P_1$  [kW], from the  $P_1$  curve with a required flow of  $Q = 160 \text{ l/s}$  and at the point of the selected impeller size,  $\varnothing = 380 \text{ mm}$ .  
 In this example, the device electrical power is  $P_1 = 74 \text{ kW}$ .

8. Energy cost = Electrical power  $P_1$  [kW] x energy price [€/ kWh] x operating time [h].

Characteristic curves apply to +20°C water.

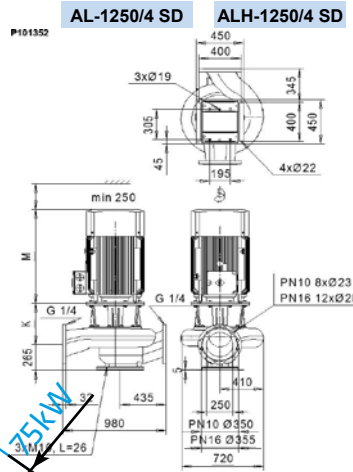

| Motor 400V | $P_{2N}$ [kW] | $I_N$ [A] | [kg] | M [mm] | K [mm] |
|------------|---------------|-----------|------|--------|--------|
| IEC-225    | 37            | 68        | 620  | 740    | 408    |
| IEC-225    | 45            | 81        | 640  | 740    | 408    |
| IEC-250    | 55            | 99        | 690  | 750    | 428    |
| IEC-280    | 75            | 134       | 900  | 950    | 428    |
| IEC-280    | 90            | 159       | 940  | 950    | 428    |

| Motor 380-400V(460-480V) | $P_{2N}$ [kW] | $I_N$ [A] | [kg] | M [mm] | K [mm] |
|--------------------------|---------------|-----------|------|--------|--------|
| IEC-225                  | 45 (54)       | 81        | 640  | 740    | 408    |
| IEC-250                  | 55 (66)       | 99        | 690  | 750    | 428    |
| IEC-280                  | 75 (90)       | 134       | 900  | 950    | 428    |
| IEC-280                  | 90 (105)      | 159       | 940  | 950    | 428    |

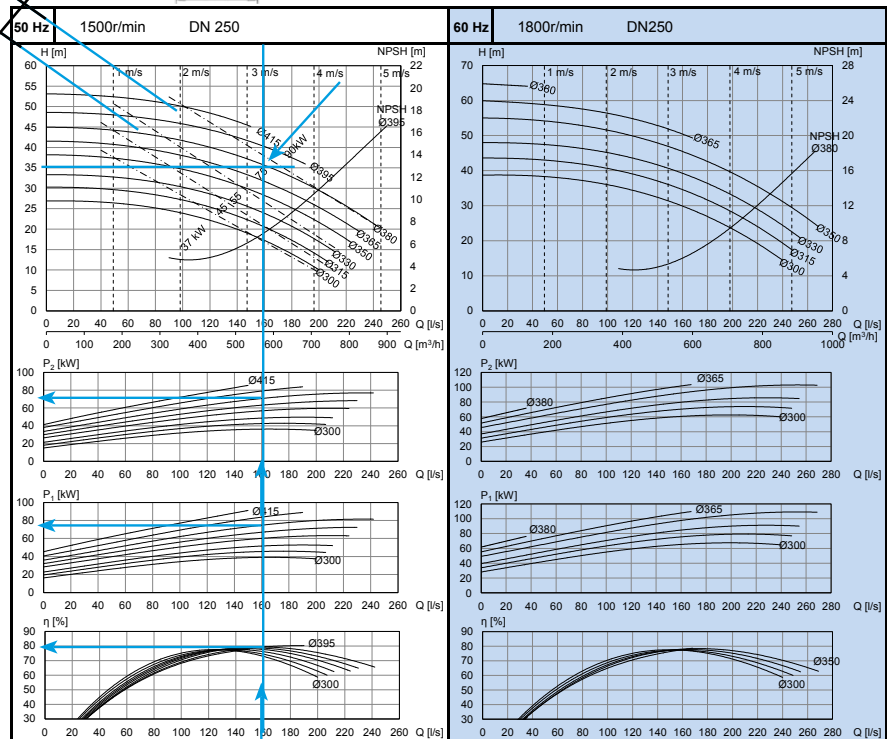

**Note! Please contact Kolmeks for additional information on the following issues!**

- When pumping liquids whose viscosity differs from that of water, the effect of viscosity must be considered in pump selection.
- Liquid density is directly proportional to the power requirement. The sufficiency of motor power must be checked for liquids denser than water.

# Selecting an optimal pump for frequency converter operation from a 60Hz curve

## CORRECTLY-SIZED PUMP

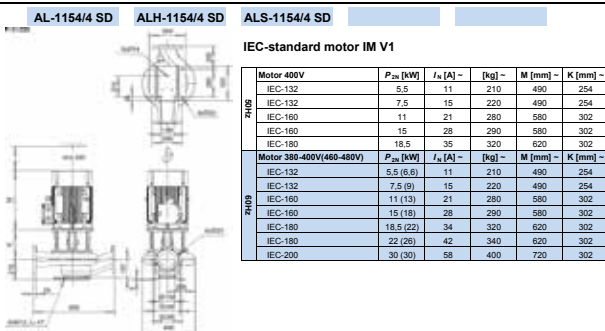

## OVERSIZED PUMP

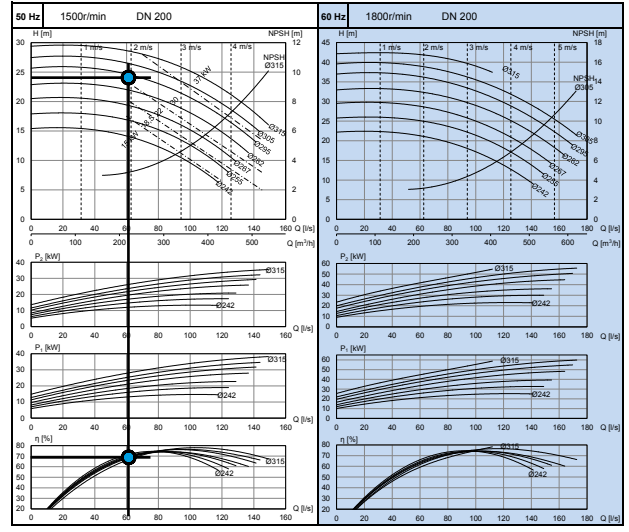
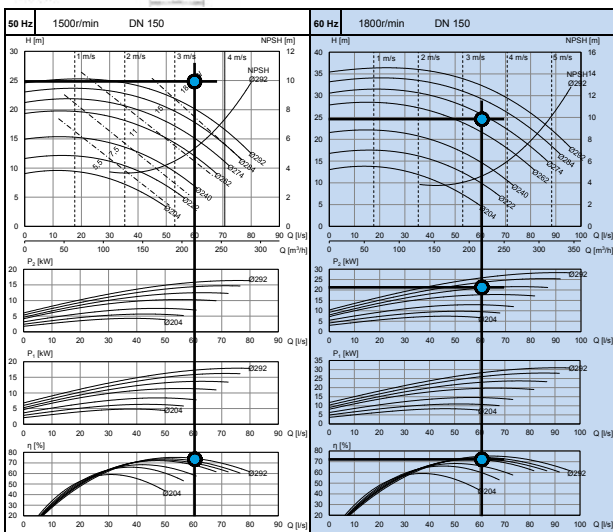
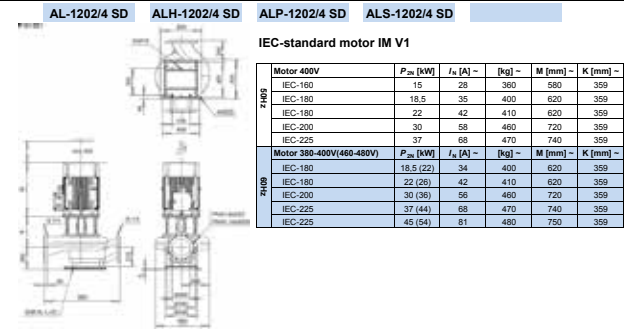

E.g. duty point: flow = 60 l/s, head = 25 m, pumped liquid being water +20°C.

1. Use the quick selection chart at the beginning of the catalogue or check the datasheets in the product catalogue to find a pump in the correct size range such that the required flow is in the best efficiency point. The AL-1154/4 SD pump is selected because its efficiency is the best in the required duty point  $\eta = 75\%$ .
2. The duty point is outside the operating range of the AL-1154/4 SD 50 Hz pump.
3. Usually when selecting the pump from the 50 Hz curve to the required higher duty point ( $Q = 60$  l/s, 25 m), the next largest pump is selected. In the above example, we choose AL-1202/4 SD,  $\varnothing 295$ mm,  $P_2N = 30$  kW,  $\eta = 67\%$ . This is an oversized pump whose best flow range is within 100–120 l/s, where its efficiency is the highest  $\eta = 80\%$ .
4. Select the pump AL-1154/4 SD, 60 Hz curve, whereby the impeller is  $\varnothing 274$ mm. The nominal motor shaft power  $P_2N$  is selected according to the shaft power curve  $P_2$ . Shaft power  $P_2 = 21$  kW and the next higher nominal power is  $P_2N = 22$  kW. In this example, we choose AL-1154/4 SD,  $\varnothing 274$ mm,  $P_2N = 22$  kW,  $\eta = 75\%$ .

QH curves are available for 50 Hz and 60 Hz on the same datasheet in order to facilitate the customer's selection of the most energy efficient pump for frequency converter operation.

## How does careful pump selection benefit the customer?

1. The pump saves energy, because it has been selected from the range of the best efficiency.
2. The total purchase cost is lower, because the pump, the electric motor and the frequency converter are one size smaller.
3. The pumps are designed to operate at the best efficiency where they run with low noise and vibration and have a long service life.
4. A smaller pump saves energy in partial flows, because its efficiency is better for the entire operating range.

# NPSH and cavitation

$NPSH_{re} < NPSH_{av}$

$NPSH_{re} < p + h - h_{suction} - p_h$

$NPSH_{re} < p_{suction} - p_h$

$NPSH_{av}$  = difference between available inlet pressure (in suction flange) and vapour pressure of liquid being pumped  
 $NPSH_{re}$  = NPSH value required by the pump  
 p = Absolute air pressure  
 $p_h$  = Absolute liquid vapour pressure at the operating temperature  
 h = Liquid geodetic suction head  
 $h_{suction}$  = Pressure losses in suction pipes  
 $p_{suction}$  = Absolute suction pressure

The  $NPSH_{av}$  value of a system refers to the actual difference between inlet pressure (in the suction flange) and vapour pressure of the liquid being pumped. The  $NPSH_{re}$  value required of the pump must be smaller than the  $NPSH_{av}$  value in order to prevent cavitation from occurring. A safety margin of 0.5 m must be added to the measurement value.

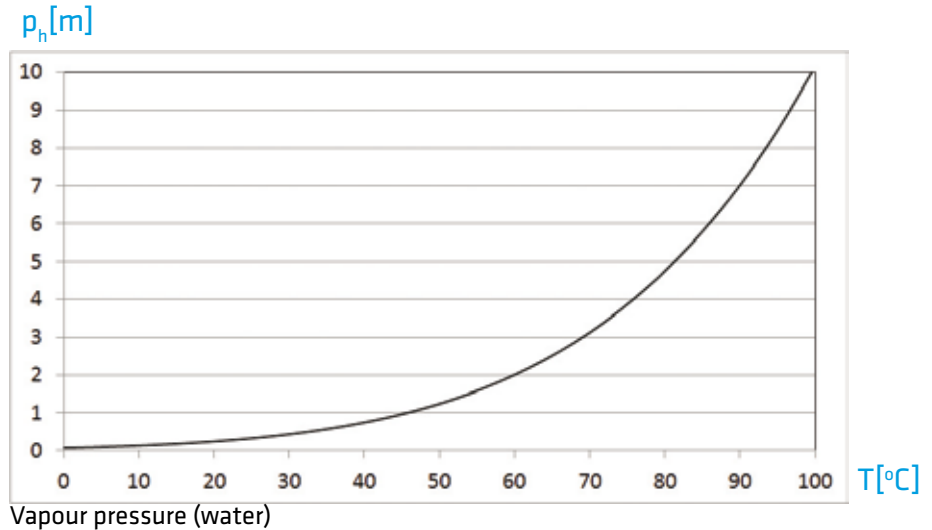

At normal air pressure levels (10 m water column, 1,013 mbar = 760 mm Hg), clean water boils at 100°C. It can be seen from the curve that water boils at 60°C when the absolute pressure is 2 m wc (i.e. 8 m wc below atmospheric pressure). The boiling point of water at less than 40°C can be achieved at a very low pressure. Vice versa, at the top of Mount Everest, where air pressure is about 0.6 bar (6 m), water boils at +85°C.

### Example:

Open tank (p = air pressure = 10 m) where the water temperature is + 90°C (p<sub>h</sub> = 7 m), suction pipe losses 1 m and liquid suction head flange +2 m. The pump duty point 20 l/s, 7.8 m.

**Is the selected pump suitable for the use in question? An example of calculation:**

Pump type:  
 AL\_-1129/4 SD Ø288 15 kW

$NPSH_{re} < p + h - h_{suction} - p_h$

$NPSH_{re} < 10\text{ m} + 2\text{ m} - 1\text{ m} - 7\text{ m}$

$NPSH_{re} < 4\text{ m}$

When observing the safety margin 0,5 m, the  $NPSH_{re}$  value of the pump must be smaller than 3,5 m in order to prevent the pump from cavitating.  $NPSH_{re}$  of pump AL\_-1129/4 SD Ø288  $NPSH_{re} = 2,7\text{ m}$  -> whereby it will not cavitate.

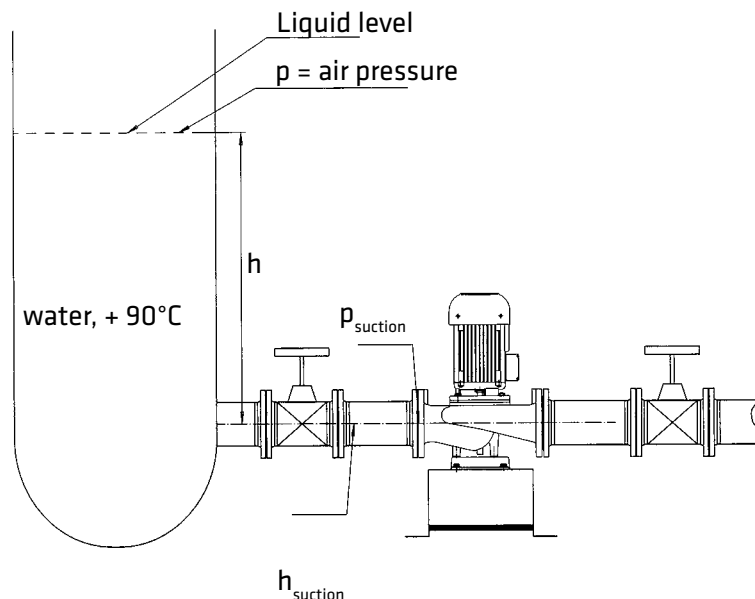



L-100S/4 SD

LH-100S/4 SD

LP-100S/4 SD

P101253

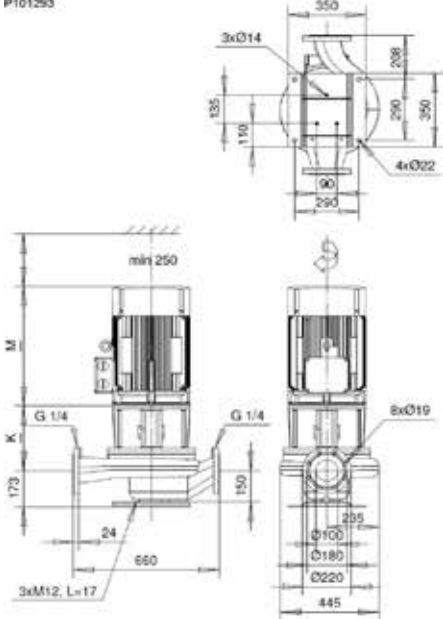

IEC-standard motor IM V1

| 50Hz | Motor 400V               | $P_{2N}$ [kW] | $I_N$ [A] ~ | [kg] ~ | M [mm] ~ | K [mm] ~ |
|------|--------------------------|---------------|-------------|--------|----------|----------|
|      |                          | IEC-132       | 5,5         | 11     | 200      | 490      |
|      | IEC-132                  | 7,5           | 15          | 210    | 490      | 260      |
|      | IEC-160                  | 11            | 21          | 270    | 580      | 308      |
|      | IEC-160                  | 15            | 28          | 280    | 580      | 308      |
| 60Hz | Motor 380-400V(460-480V) | $P_{2N}$ [kW] | $I_N$ [A] ~ | [kg] ~ | M [mm] ~ | K [mm] ~ |
|      | IEC-132                  | 5,5 (6,6)     | 11          | 200    | 490      | 260      |
|      | IEC-132                  | 7,5 (9)       | 15          | 210    | 490      | 260      |
|      | IEC-160                  | 11 (13)       | 21          | 270    | 580      | 308      |
|      | IEC-160                  | 15 (18)       | 28          | 280    | 580      | 308      |
|      | IEC-180                  | 18,5 (22)     | 34          | 310    | 620      | 308      |
|      | IEC-180                  | 22 (26)       | 42          | 330    | 620      | 308      |

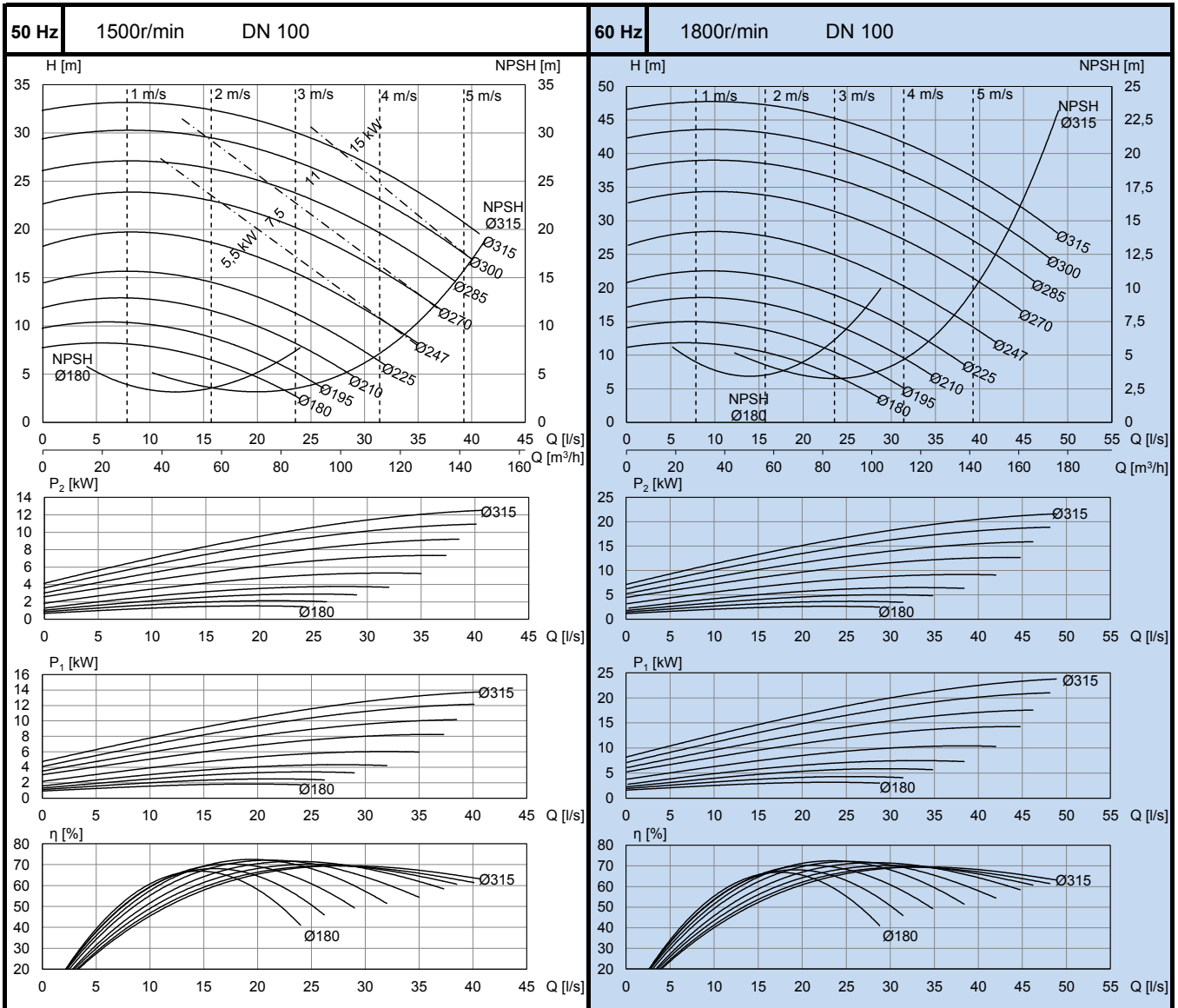



L-100S/2 SD

LH-100S/2 SD

LP-100S/2 SD

P101274

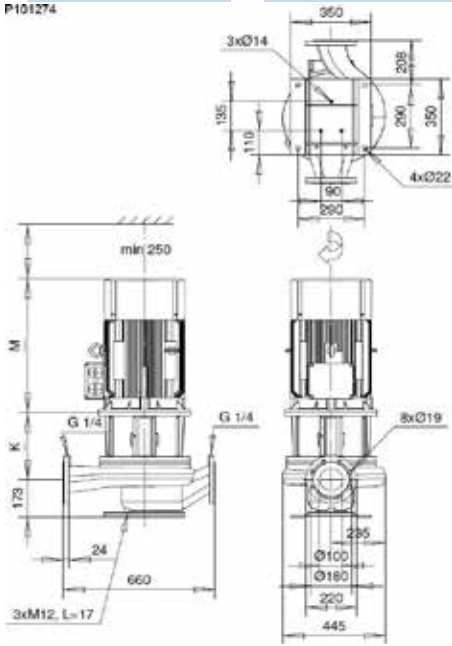

IEC-standard motor IM V1

| 50Hz    | Motor 400V | $P_{2N}$ [kW] | $I_N$ [A] ~ | [kg] ~ | M [mm] ~ | K [mm] ~ |
|---------|------------|---------------|-------------|--------|----------|----------|
|         | IEC-160    | 15            | 27          | 260    | 580      | 308      |
| IEC-160 | 18,5       | 33            | 270         | 620    | 308      |          |
| IEC-180 | 22         | 39            | 330         | 620    | 308      |          |
| IEC-200 | 30         | 53            | 370         | 720    | 308      |          |
| IEC-200 | 37         | 65            | 390         | 720    | 308      |          |
| IEC-225 | 45         | 78            | 440         | 740    | 308      |          |

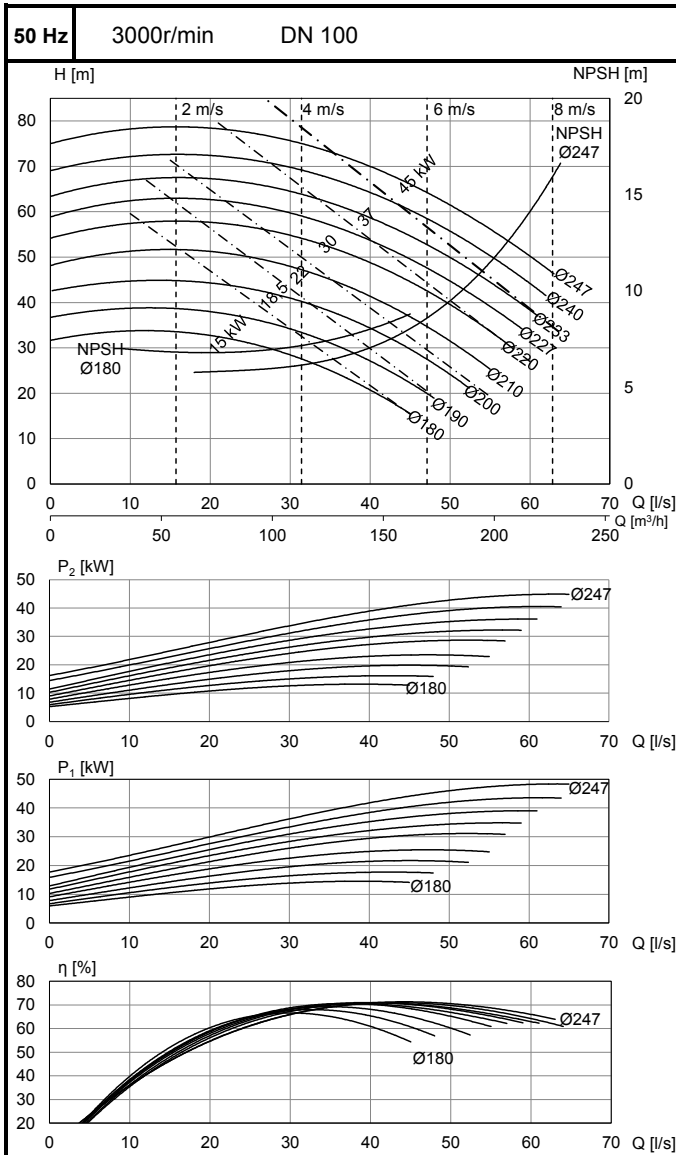

AL-1129/4 SD

ALH-1129/4 SD

ALS-1129/4 SD

P101204

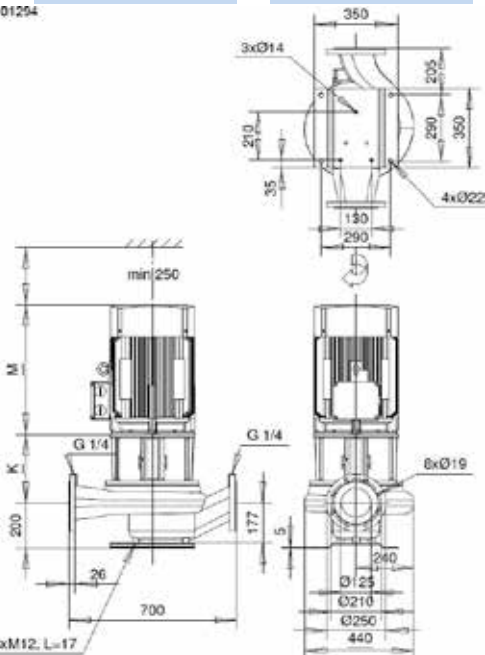

IEC-standard motor IM V1

| 50Hz    | Motor 400V               | $P_{2N}$ [kW] | $I_N$ [A] ~ | [kg] ~ | M [mm] ~ | K [mm] ~ |
|---------|--------------------------|---------------|-------------|--------|----------|----------|
|         | IEC-132                  | 5,5           | 11          | 200    | 490      | 252      |
| IEC-132 | 7,5                      | 15            | 210         | 490    | 252      |          |
| IEC-160 | 11                       | 21            | 270         | 580    | 300      |          |
| IEC-160 | 15                       | 28            | 280         | 580    | 300      |          |
| 60Hz    | Motor 380-400V(460-480V) | $P_{2N}$ [kW] | $I_N$ [A] ~ | [kg] ~ | M [mm] ~ | K [mm] ~ |
|         | IEC-132                  | 5,5 (6,6)     | 11          | 200    | 490      | 252      |
|         | IEC-132                  | 7,5 (9)       | 15          | 210    | 490      | 252      |
|         | IEC-160                  | 11 (13)       | 21          | 270    | 580      | 300      |
|         | IEC-160                  | 15 (18)       | 28          | 280    | 580      | 300      |
|         | IEC-180                  | 18,5 (22)     | 34          | 320    | 620      | 300      |
| IEC-180 | 22 (26)                  | 42            | 330         | 620    | 300      |          |

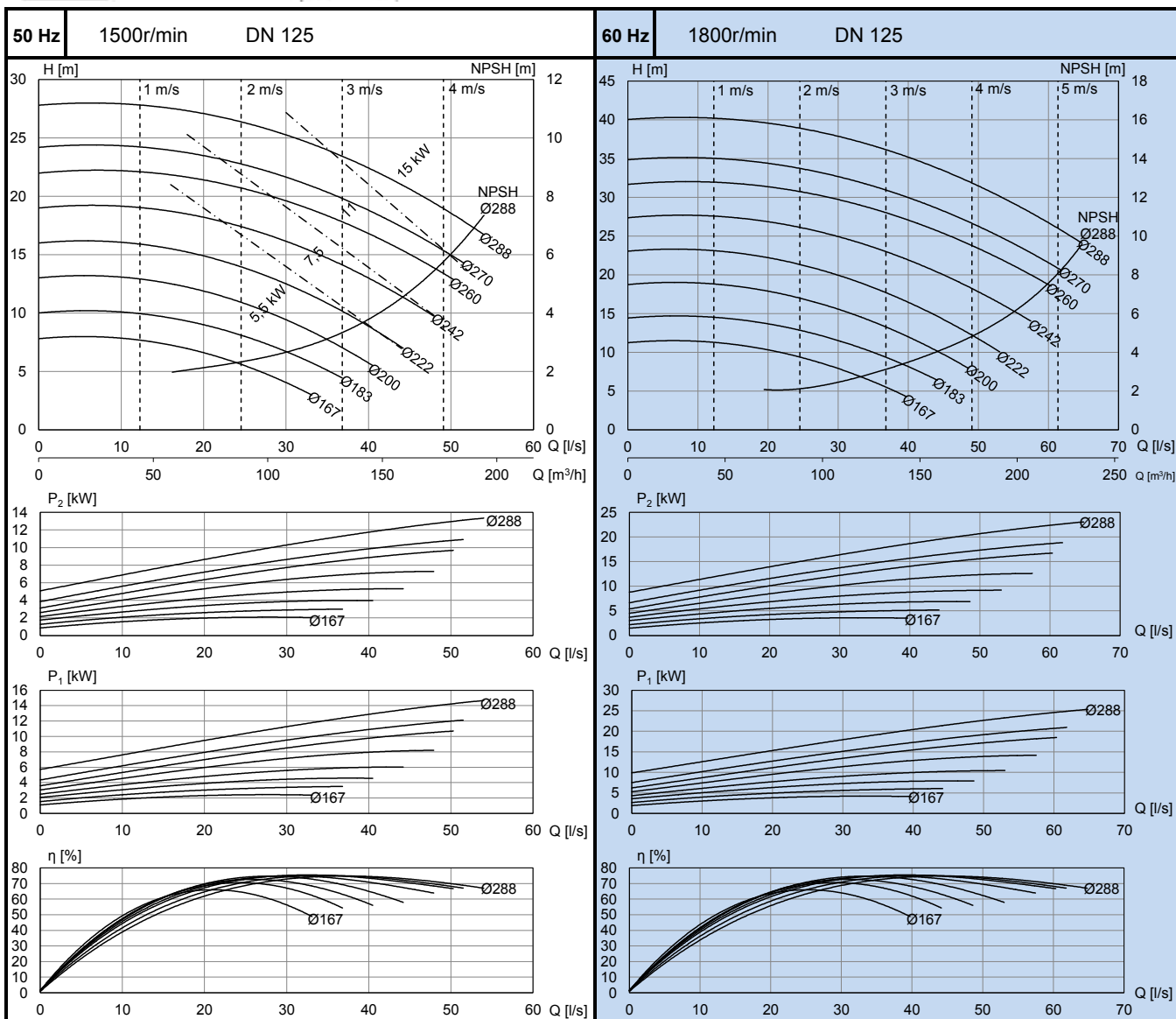

AL-1129/2 SD

ALH-1129/2 SD

ALS-1129/2 SD

P101284

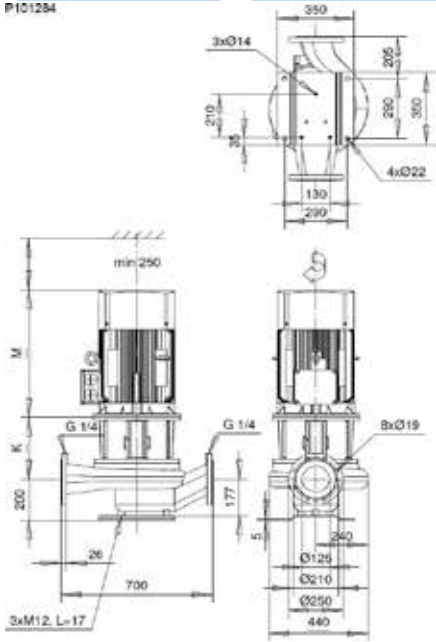

IEC-standard motor IM V1

| 50Hz | Motor 400V | $P_{2N}$ [kW] | $I_N$ [A] ~ | [kg] ~ | M [mm] ~ | K [mm] ~ |
|------|------------|---------------|-------------|--------|----------|----------|
|      | IEC-200    | 30            | 53          | 370    | 720      | 300      |
|      | IEC-200    | 37            | 65          | 400    | 720      | 300      |

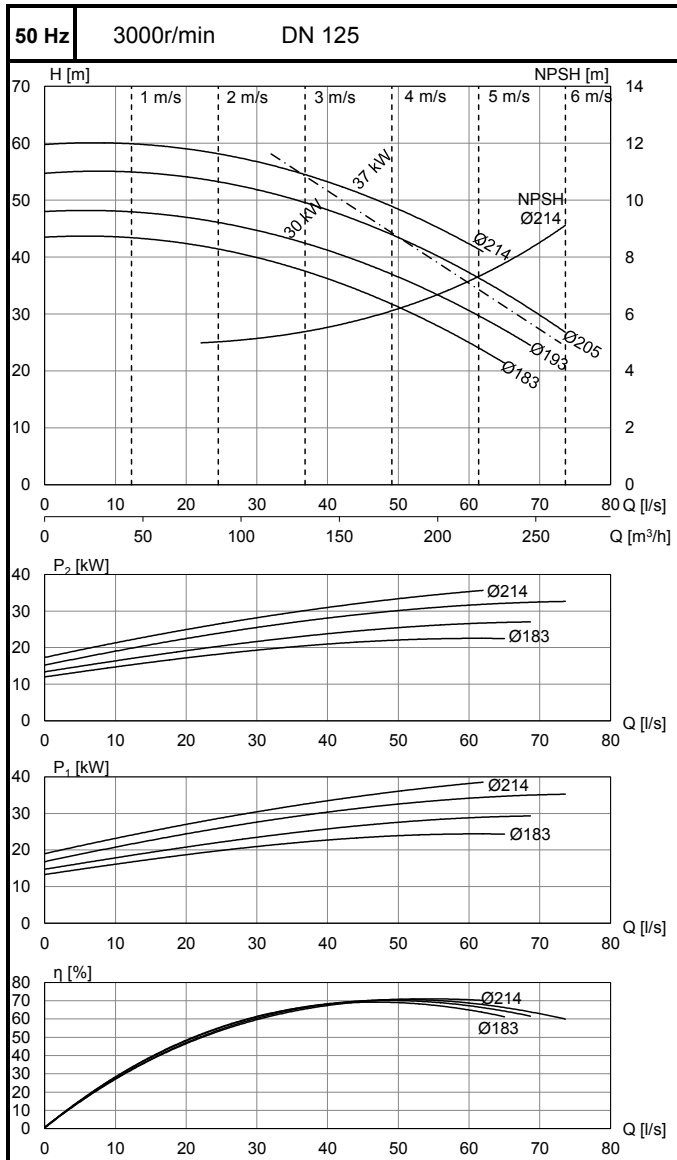

**ALP-1128/4 SD**

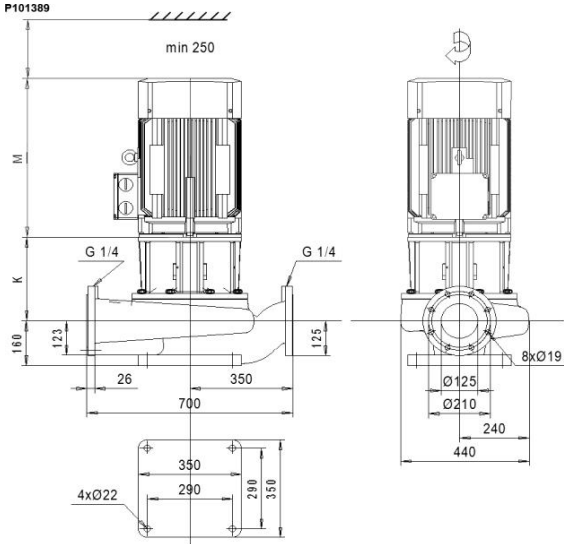

**IEC-standard motor IM V1**

|         | Motor 400V               |           | $P_{2N}$ [kW] | $I_N$ [A] ~ | [kg] ~ | M [mm] ~ | K [mm] ~ |
|---------|--------------------------|-----------|---------------|-------------|--------|----------|----------|
|         | ZH05                     | IEC-132   | 5,5           | 11          | 200    | 490      | 252      |
| IEC-132 |                          | 7,5       | 15            | 210         | 490    | 252      |          |
| IEC-160 |                          | 11        | 21            | 270         | 580    | 300      |          |
| IEC-160 |                          | 15        | 28            | 280         | 580    | 300      |          |
|         | Motor 380-400V(460-480V) |           | $P_{2N}$ [kW] | $I_N$ [A] ~ | [kg] ~ | M [mm] ~ | K [mm] ~ |
|         | ZH06                     | IEC-132   | 5,5 (6,6)     | 11          | 200    | 490      | 252      |
| IEC-132 |                          | 7,5 (9)   | 15            | 210         | 490    | 252      |          |
| IEC-160 |                          | 11 (13)   | 21            | 270         | 580    | 300      |          |
| IEC-160 |                          | 15 (18)   | 28            | 280         | 580    | 300      |          |
| IEC-180 |                          | 18,5 (22) | 34            | 320         | 620    | 300      |          |
| IEC-180 |                          | 22 (26)   | 42            | 330         | 620    | 300      |          |

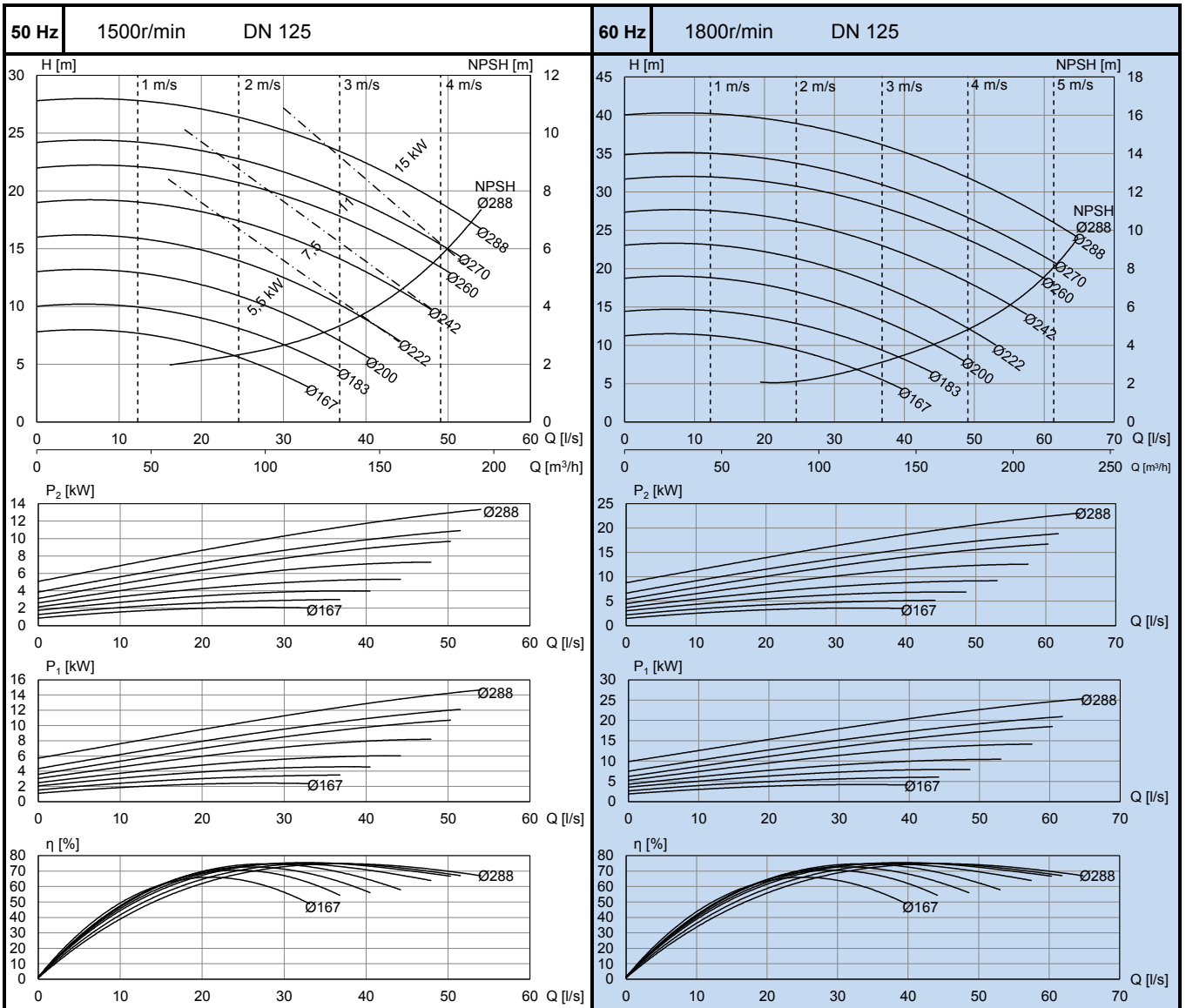

ALP-1128/2 SD

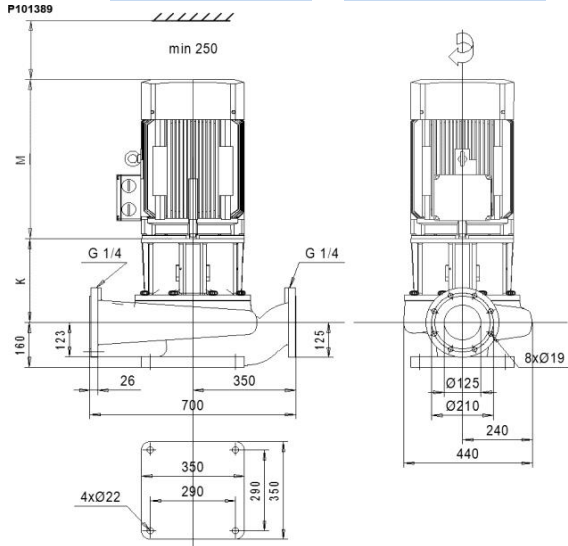

IEC-standard motor IM V1

| 50 Hz   | Motor 400V | $P_{2N}$ [kW] | $I_N$ [A] ~ | [kg] ~ | M [mm] ~ | K [mm] ~ |
|---------|------------|---------------|-------------|--------|----------|----------|
|         | IEC-200    | 30            | 53          | 370    | 720      | 300      |
| IEC-200 | 37         | 65            | 400         | 720    | 300      |          |

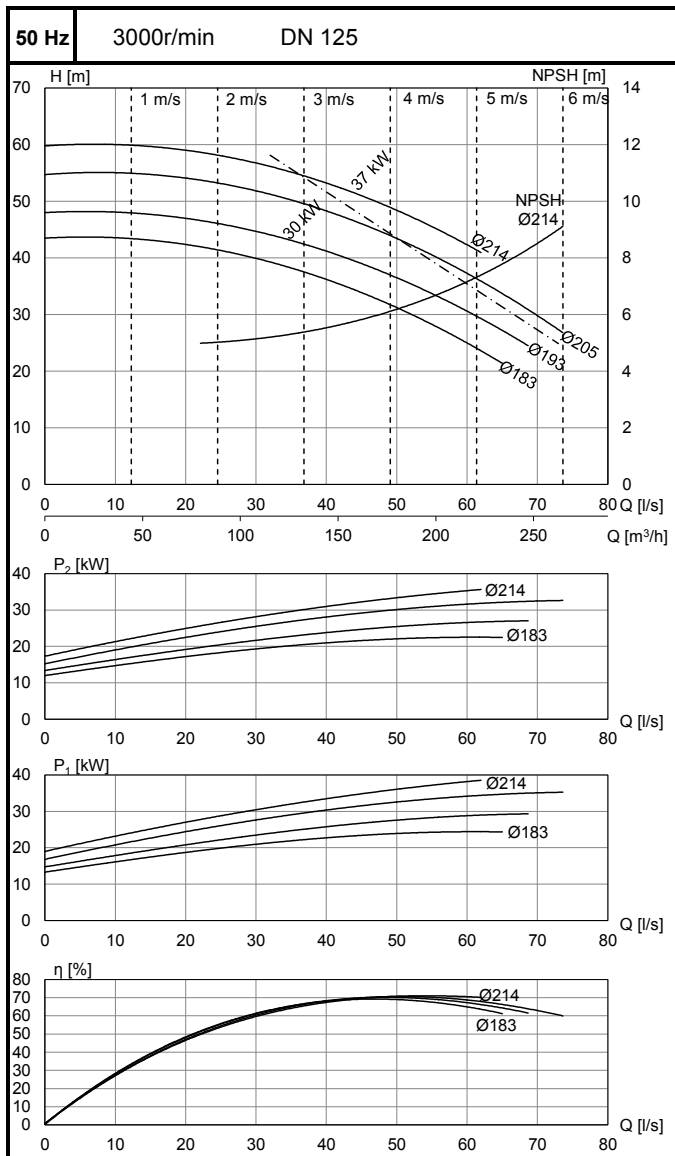



**ALP-1153/6 SD**

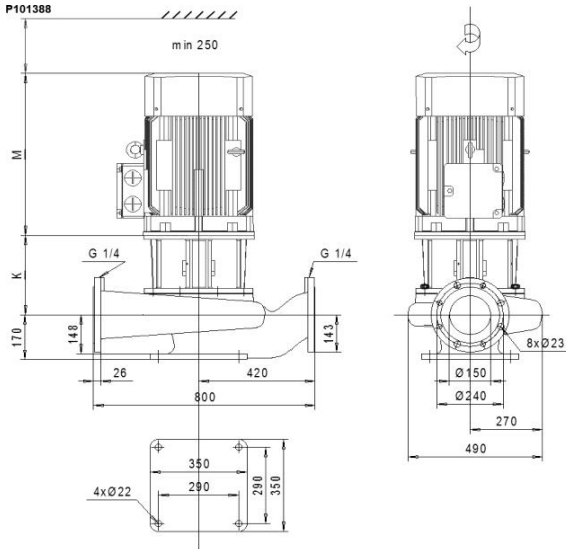

**IEC-standard motor IM V1**

| 50Hz    | Motor 400V               | $P_{2N}$ [kW] | $I_N$ [A] ~ | [kg] ~ | M [mm] ~ | K [mm] ~ |
|---------|--------------------------|---------------|-------------|--------|----------|----------|
|         | IEC-132                  | 4             | 9           | 210    | 490      | 254      |
| IEC-132 | 5,5                      | 12            | 220         | 490    | 254      |          |
| 60Hz    | Motor 380-400V(460-480V) | $P_{2N}$ [kW] | $I_N$ [A] ~ | [kg] ~ | M [mm] ~ | K [mm] ~ |
|         | IEC-132                  | 4 (4,8)       | 9           | 210    | 490      | 254      |
|         | IEC-132                  | 5,5 (6,6)     | 12          | 220    | 490      | 254      |
|         | IEC-160                  | 7,5 (9)       | 16          | 270    | 580      | 302      |
| IEC-160 | 11 (13)                  | 23            | 280         | 580    | 302      |          |

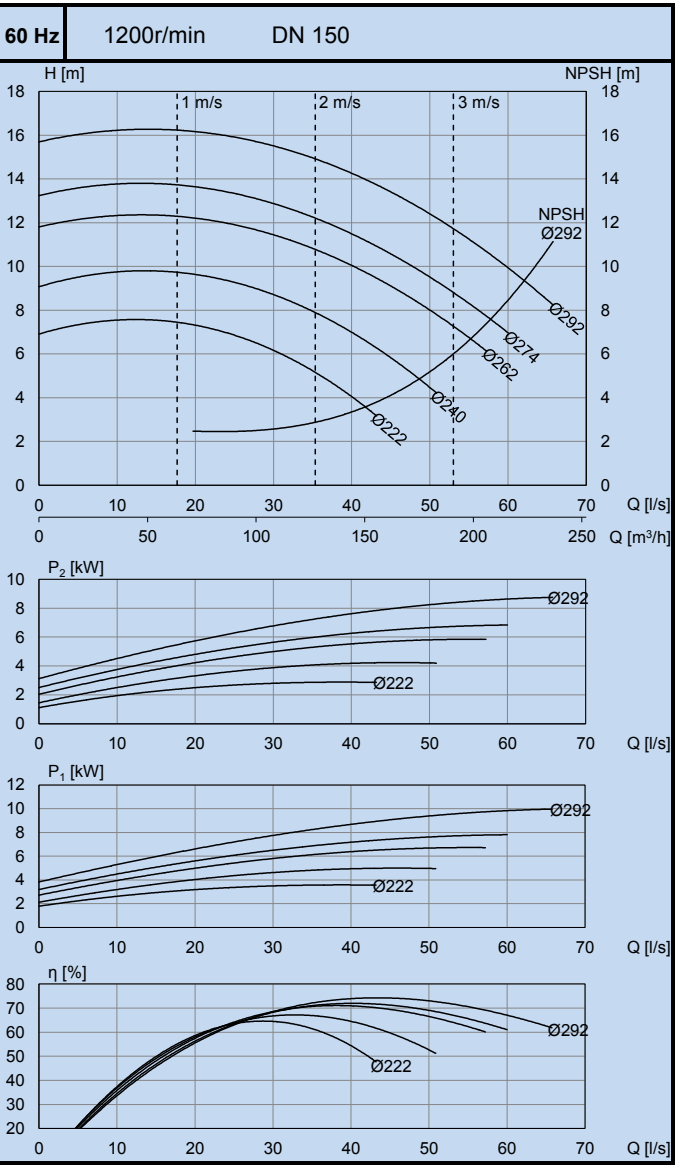
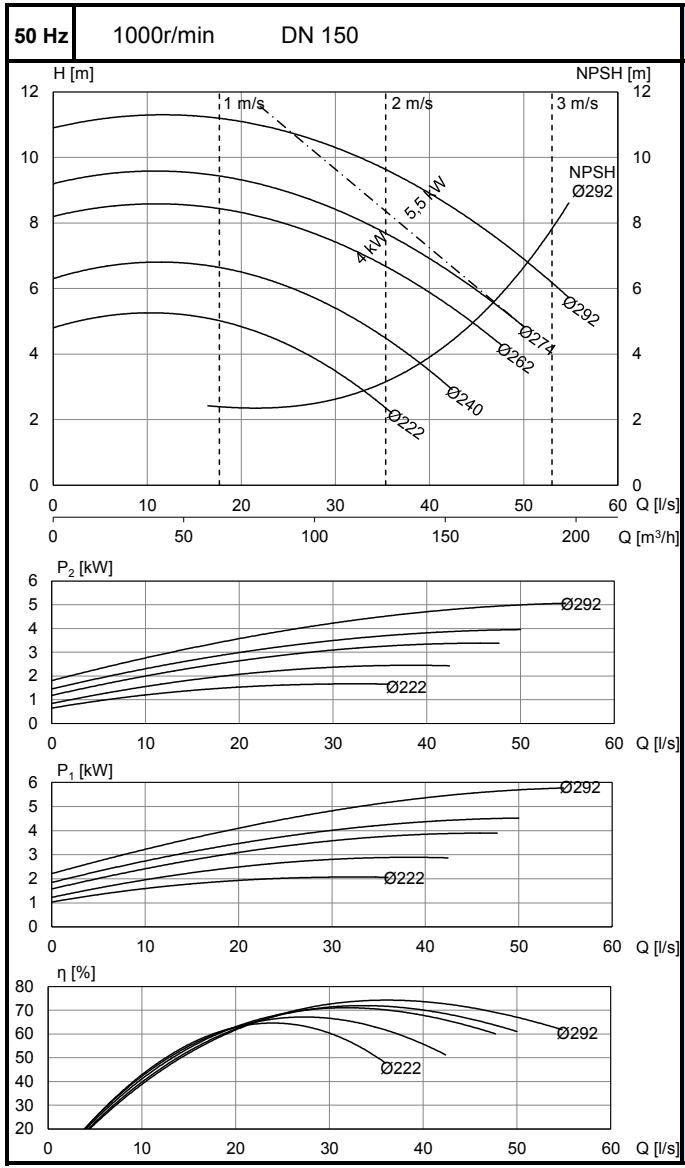



ALP-1153/4 SD

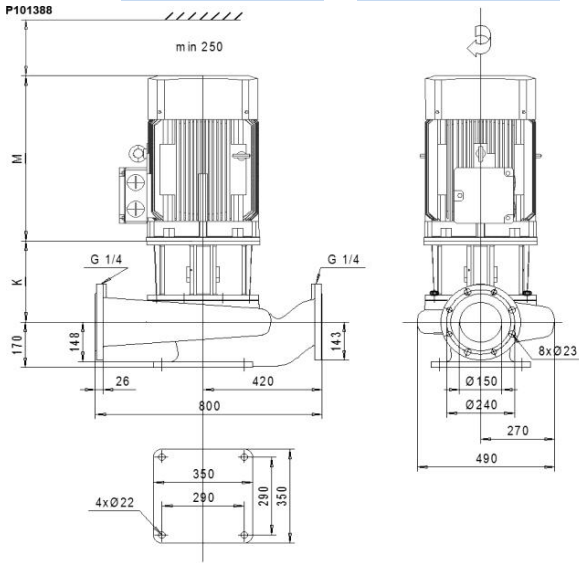

IEC-standard motor IM V1

|         | Motor 400V               | $P_{2N}$ [kW] | $I_N$ [A] ~ | [kg] ~ | M [mm] ~ | K [mm] ~ |
|---------|--------------------------|---------------|-------------|--------|----------|----------|
|         | 5H09                     | IEC-132       | 5,5         | 11     | 210      | 490      |
| IEC-132 |                          | 7,5           | 15          | 220    | 490      | 254      |
| IEC-160 |                          | 11            | 21          | 280    | 580      | 302      |
| IEC-160 |                          | 15            | 28          | 290    | 580      | 302      |
| IEC-180 |                          | 18,5          | 35          | 320    | 620      | 302      |
|         | Motor 380-400V(460-480V) | $P_{2N}$ [kW] | $I_N$ [A] ~ | [kg] ~ | M [mm] ~ | K [mm] ~ |
|         | 6H09                     | IEC-132       | 5,5 (6,6)   | 11     | 210      | 490      |
| IEC-132 |                          | 7,5 (9)       | 15          | 220    | 490      | 254      |
| IEC-160 |                          | 11 (13)       | 21          | 280    | 580      | 302      |
| IEC-160 |                          | 15 (18)       | 28          | 290    | 580      | 302      |
| IEC-180 |                          | 18,5 (22)     | 34          | 320    | 620      | 302      |
| IEC-180 |                          | 22 (26)       | 42          | 340    | 620      | 302      |
| IEC-200 |                          | 30 (30)       | 58          | 400    | 720      | 302      |

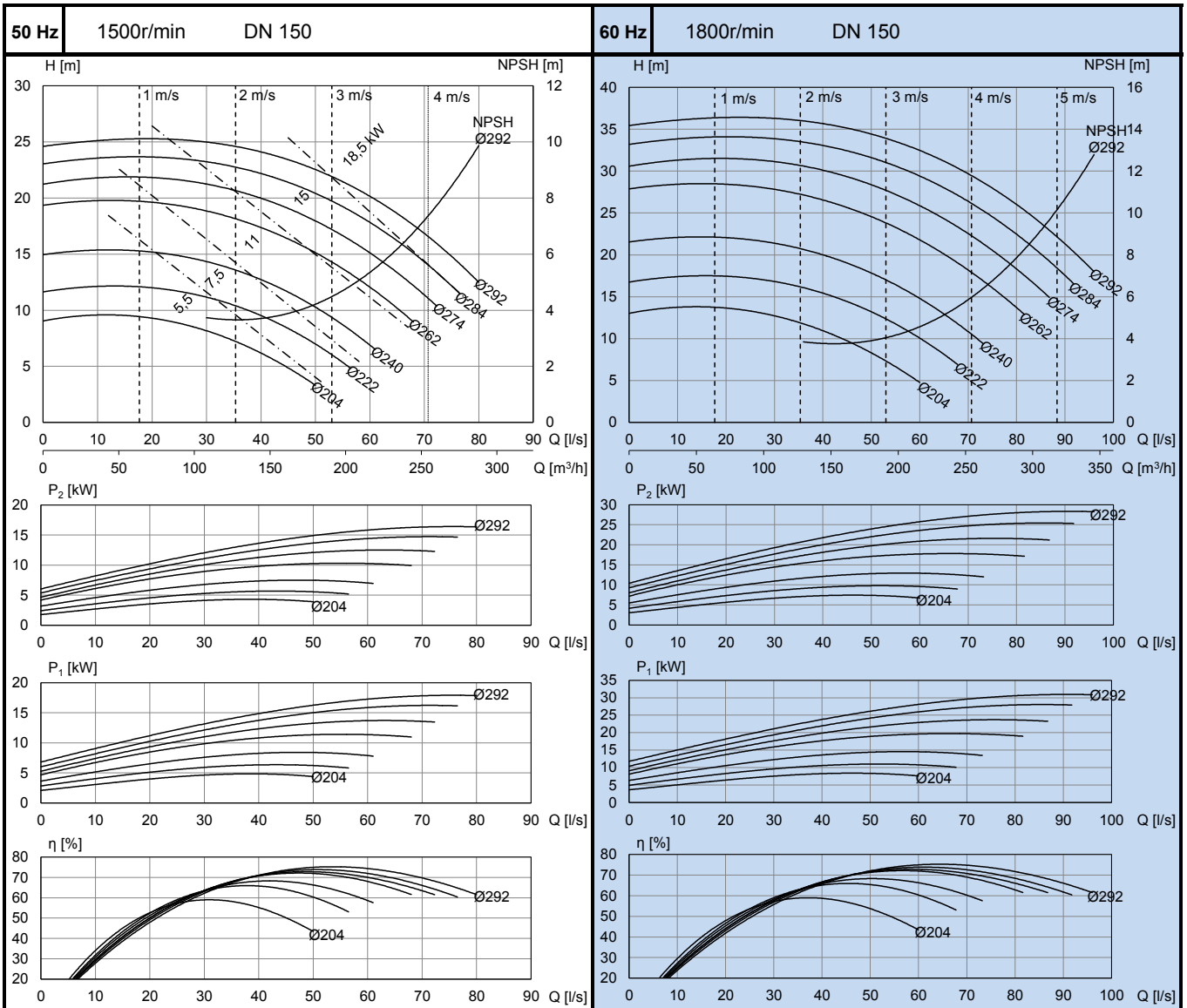

AL-1154/6 SD

ALH-1154/6 SD

ALS-1154/6 SD

F101286

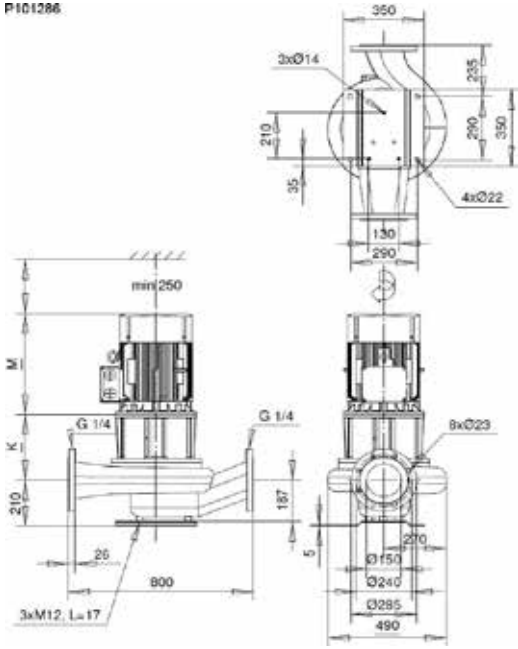

IEC-standard motor IM V1

| 50Hz    | Motor 400V               | $P_{2N}$ [kW] | $I_N$ [A] ~ | [kg] ~ | M [mm] ~ | K [mm] ~ |
|---------|--------------------------|---------------|-------------|--------|----------|----------|
|         | IEC-132                  | 4             | 9           | 210    | 490      | 254      |
| IEC-132 | 5,5                      | 12            | 220         | 490    | 254      |          |
| 60Hz    | Motor 380-400V(460-480V) | $P_{2N}$ [kW] | $I_N$ [A] ~ | [kg] ~ | M [mm] ~ | K [mm] ~ |
|         | IEC-132                  | 4 (4,8)       | 9           | 210    | 490      | 254      |
|         | IEC-132                  | 5,5 (6,6)     | 12          | 220    | 490      | 254      |
|         | IEC-160                  | 7,5 (9)       | 16          | 270    | 580      | 302      |
| IEC-160 | 11 (13)                  | 23            | 280         | 580    | 302      |          |

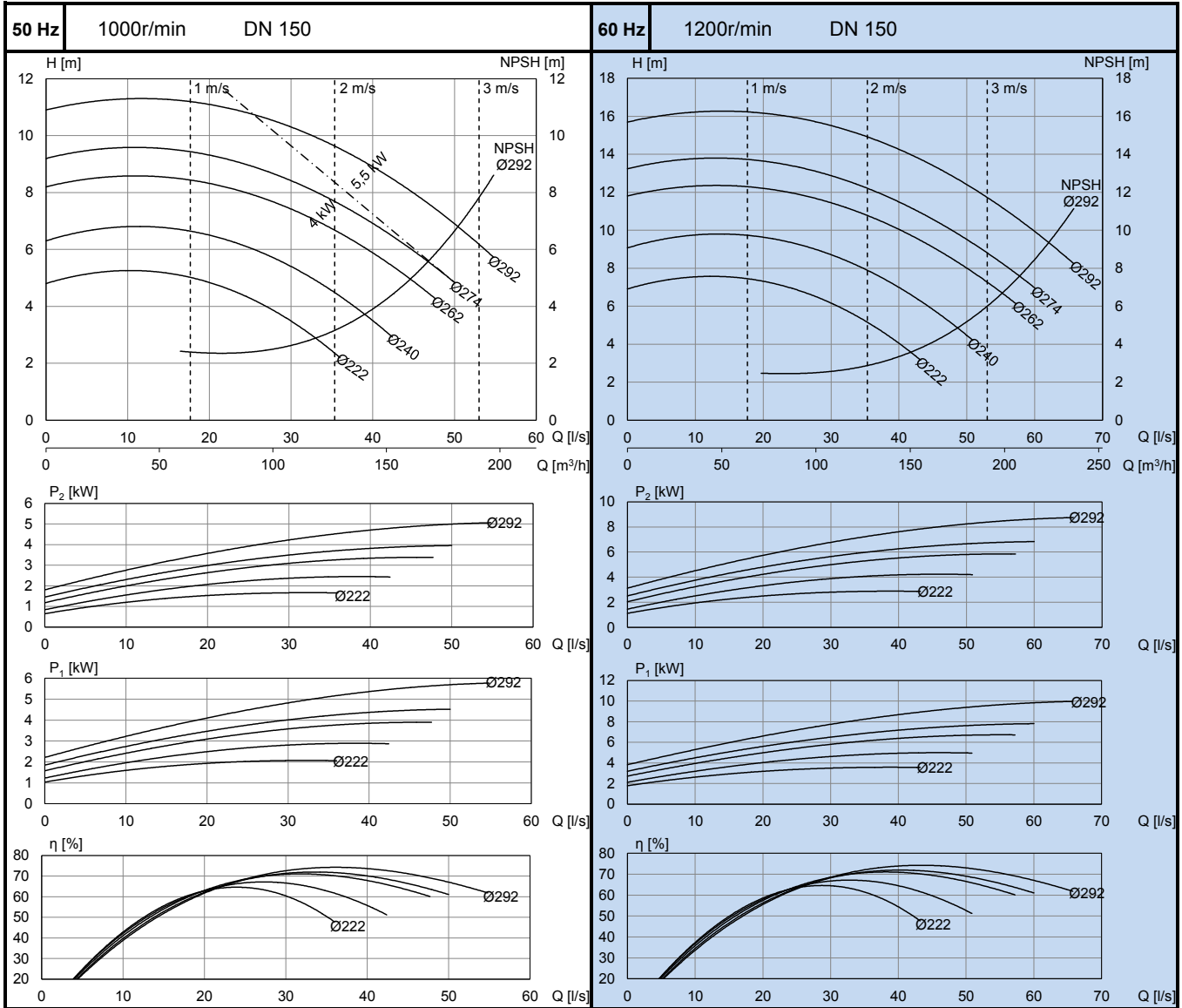

AL-1154/4 SD

ALH-1154/4 SD

ALS-1154/4 SD

P101289

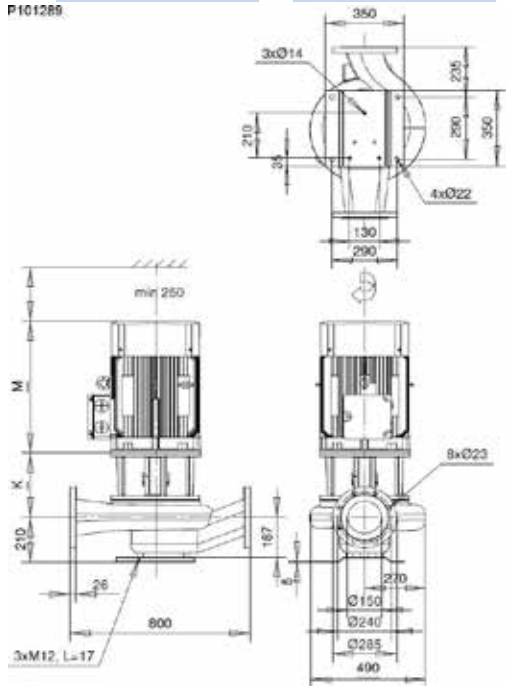

IEC-standard motor IM V1

| Motor 400V               | $P_{2N}$ [kW] | $I_N$ [A] ~ | [kg] ~ | M [mm] ~ | K [mm] ~ |
|--------------------------|---------------|-------------|--------|----------|----------|
|                          | IEC-132       | 5,5         | 11     | 210      | 490      |
| IEC-132                  | 7,5           | 15          | 220    | 490      | 254      |
| IEC-160                  | 11            | 21          | 280    | 580      | 302      |
| IEC-160                  | 15            | 28          | 290    | 580      | 302      |
| IEC-180                  | 18,5          | 35          | 320    | 620      | 302      |
| Motor 380-400V(460-480V) | $P_{2N}$ [kW] | $I_N$ [A] ~ | [kg] ~ | M [mm] ~ | K [mm] ~ |
| IEC-132                  | 5,5 (6,6)     | 11          | 210    | 490      | 254      |
| IEC-132                  | 7,5 (9)       | 15          | 220    | 490      | 254      |
| IEC-160                  | 11 (13)       | 21          | 280    | 580      | 302      |
| IEC-160                  | 15 (18)       | 28          | 290    | 580      | 302      |
| IEC-180                  | 18,5 (22)     | 34          | 320    | 620      | 302      |
| IEC-180                  | 22 (26)       | 42          | 340    | 620      | 302      |
| IEC-200                  | 30 (30)       | 58          | 400    | 720      | 302      |

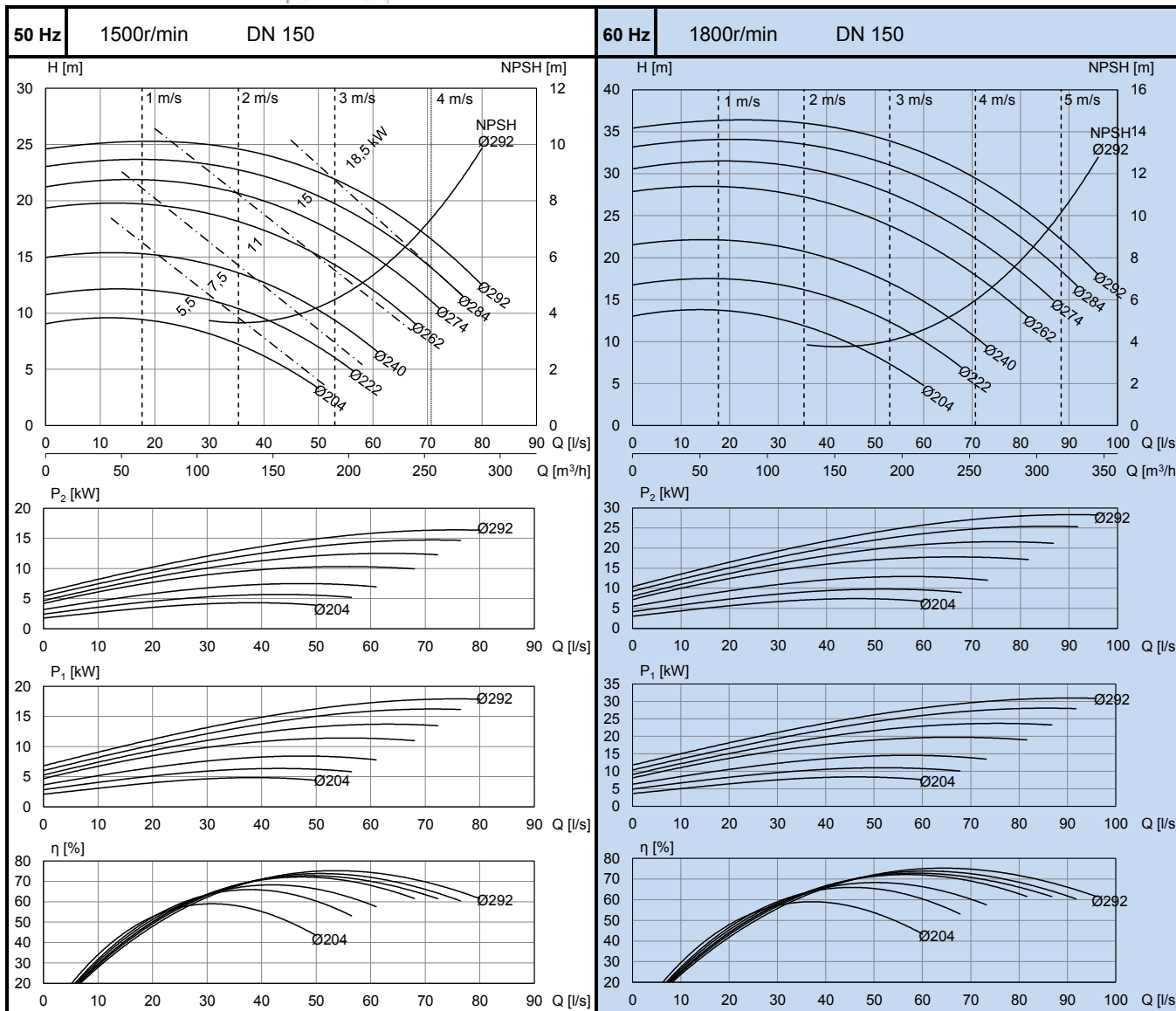

AL-1202/6 SD

ALH-1202/6 SD

ALP-1202/6 SD

ALS-1202/6 SD

P101299

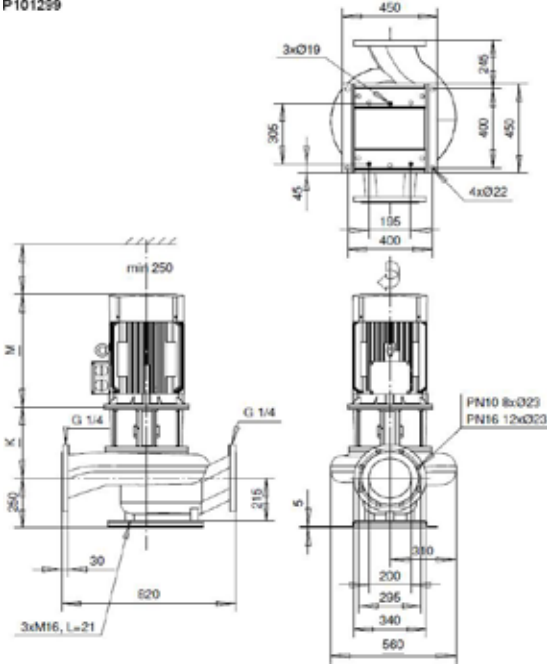

## IEC-standard motor IM V1

| ZH05    | Motor 400V               | $P_{2N}$ [kW] | $I_N$ [A] ~ | [kg] ~ | M [mm] ~ | K [mm] ~ |
|---------|--------------------------|---------------|-------------|--------|----------|----------|
|         | IEC-132                  | 4             | 9           | 300    | 490      | 311      |
| IEC-132 | 5,5                      | 12            | 310         | 490    | 311      |          |
| IEC-160 | 7,5                      | 16            | 340         | 580    | 359      |          |
| IEC-160 | 11                       | 23            | 350         | 580    | 359      |          |
| ZH09    | Motor 380-400V(460-480V) | $P_{2N}$ [kW] | $I_N$ [A] ~ | [kg] ~ | M [mm] ~ | K [mm] ~ |
|         | IEC-132                  | 4 (4,8)       | 9           | 300    | 490      | 311      |
|         | IEC-132                  | 5,5 (6,6)     | 12          | 310    | 490      | 311      |
|         | IEC-160                  | 7,5 (9)       | 16          | 340    | 580      | 359      |
|         | IEC-160                  | 11 (13)       | 23          | 350    | 580      | 359      |
|         | IEC-200                  | 18,5 (22)     | 37          | 470    | 720      | 359      |

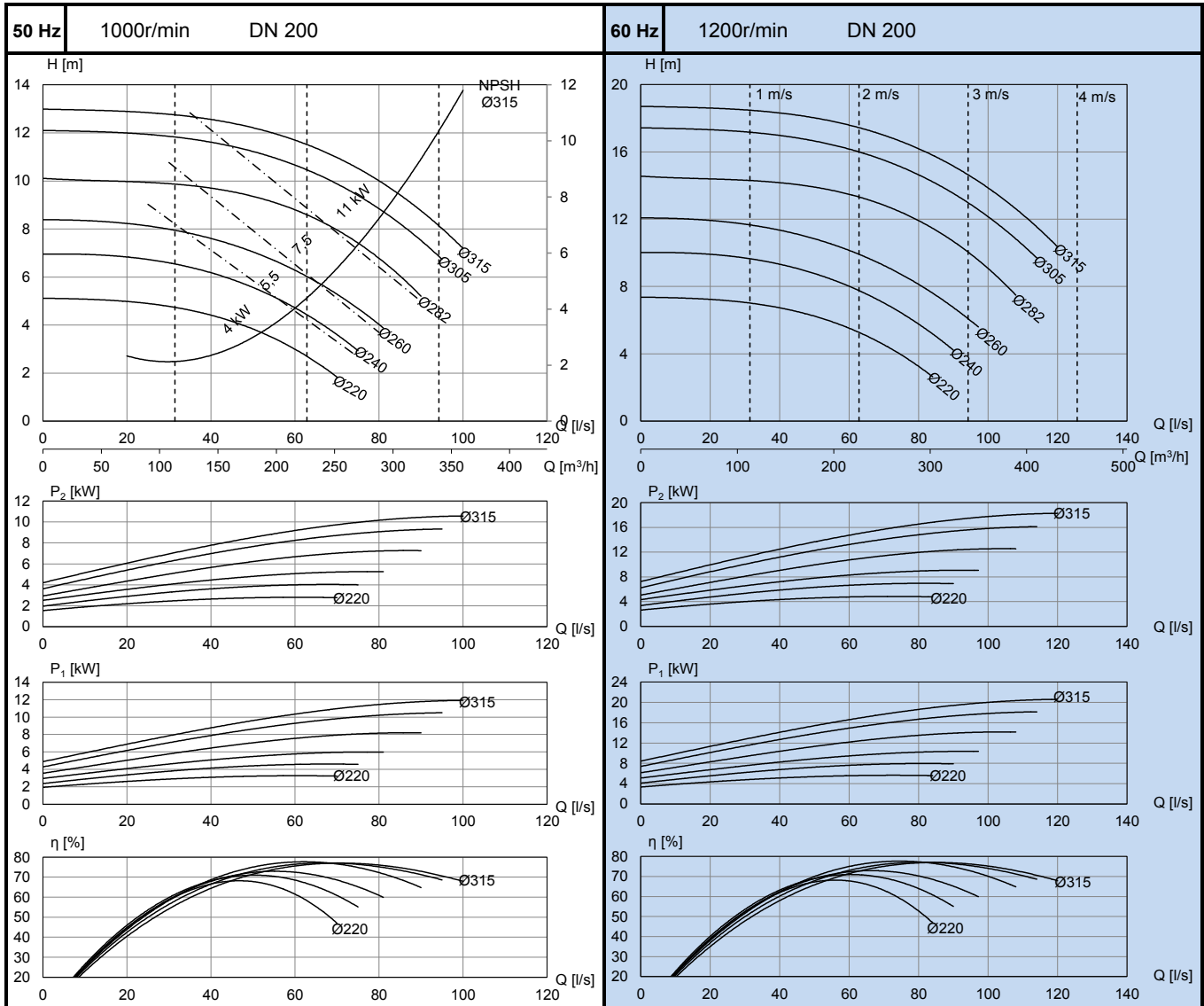

AL-1202/4 SD

ALH-1202/4 SD

ALP-1202/4 SD

ALS-1202/4 SD

P101301

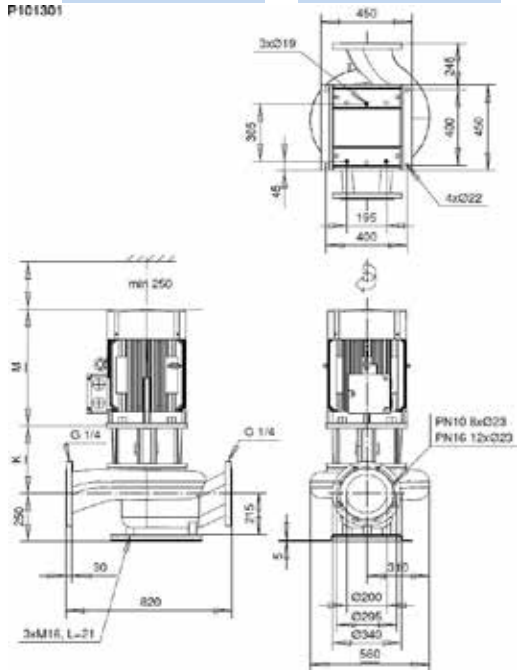

IEC-standard motor IM V1

|         | Motor 400V               |         | $P_{2N}$ [kW] | $I_N$ [A] ~ | [kg] ~ | M [mm] ~ | K [mm] ~ |
|---------|--------------------------|---------|---------------|-------------|--------|----------|----------|
|         | ZH05                     | IEC-160 | 15            | 28          | 360    | 580      | 359      |
| IEC-180 |                          | 18,5    | 35            | 400         | 620    | 359      |          |
| IEC-180 |                          | 22      | 42            | 410         | 620    | 359      |          |
| IEC-200 |                          | 30      | 58            | 460         | 720    | 359      |          |
| IEC-225 |                          | 37      | 68            | 470         | 740    | 359      |          |
|         | Motor 380-400V(460-480V) |         | $P_{2N}$ [kW] | $I_N$ [A] ~ | [kg] ~ | M [mm] ~ | K [mm] ~ |
|         | ZH09                     | IEC-180 | 18,5 (22)     | 34          | 400    | 620      | 359      |
| IEC-180 |                          | 22 (26) | 42            | 410         | 620    | 359      |          |
| IEC-200 |                          | 30 (36) | 56            | 460         | 720    | 359      |          |
| IEC-225 |                          | 37 (44) | 68            | 470         | 740    | 359      |          |
| IEC-225 |                          | 45 (54) | 81            | 480         | 750    | 359      |          |

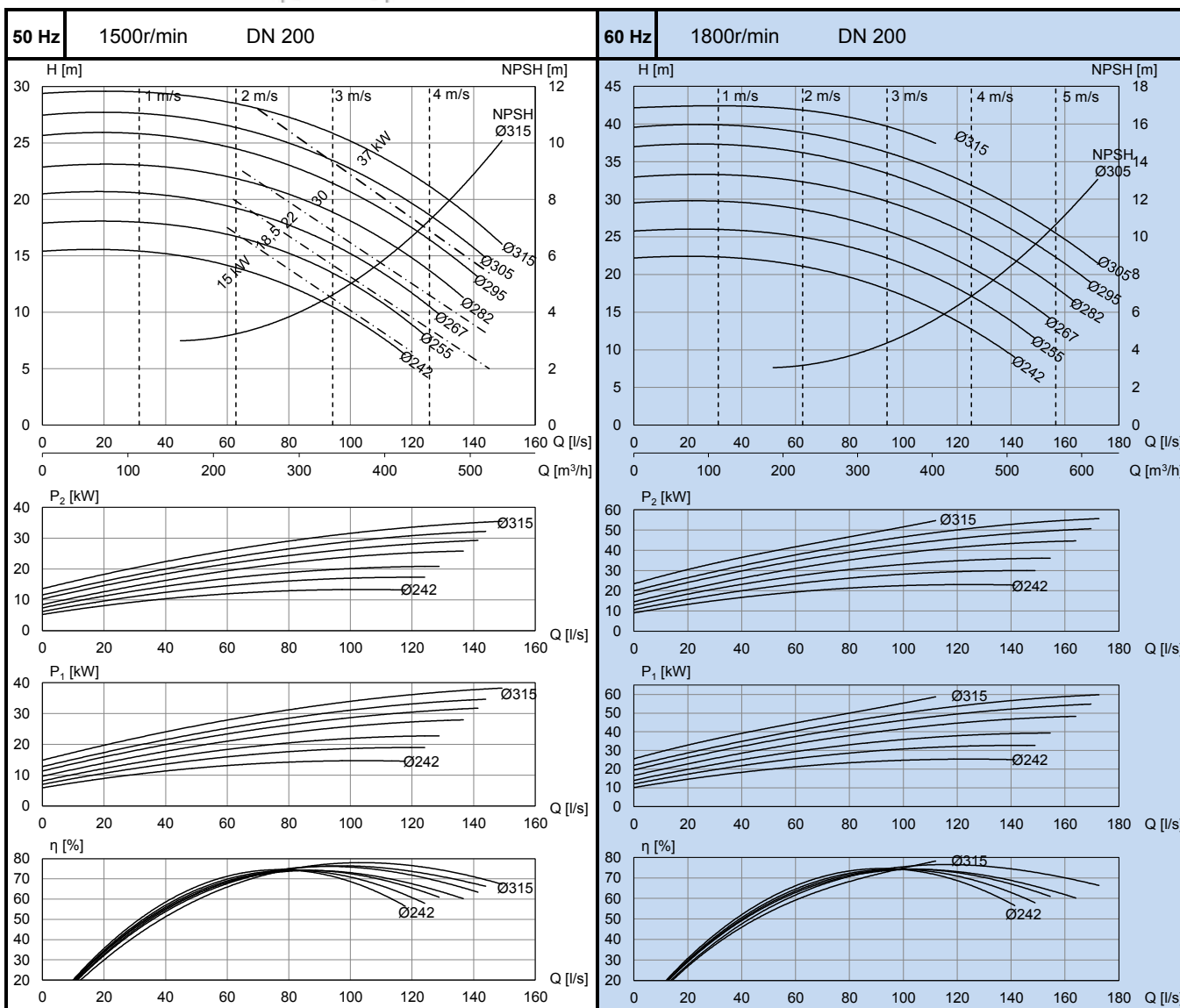

AL-1250/6 SD

ALH-1250/6 SD

ALS-1250/6 SD

P101310

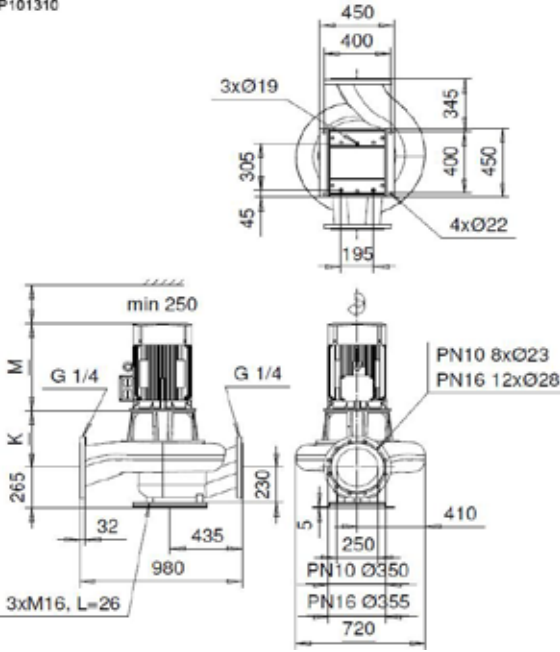

IEC-standard motor IM V1

| ZH0S | Motor 400V               | $P_{2N}$ [kW] | $I_N$ [A] ~ | [kg] ~ | M [mm] ~ | K [mm] ~ |
|------|--------------------------|---------------|-------------|--------|----------|----------|
|      | IEC-180                  | 15            | 31          | 510    | 620      | 370      |
|      | IEC-200                  | 18,5          | 37          | 580    | 720      | 370      |
|      | IEC-225                  | 22            | 42          | 590    | 720      | 370      |
| ZH0S | Motor 380-400V(460-480V) | $P_{2N}$ [kW] | $I_N$ [A] ~ | [kg] ~ | M [mm] ~ | K [mm] ~ |
|      | IEC-200                  | 18,5 (22)     | 37          | 580    | 720      | 370      |
|      | IEC-200                  | 22 (26)       | 42          | 590    | 720      | 370      |
|      | IEC-200                  | 30 (36)       | 57          | 640    | 740      | 370      |

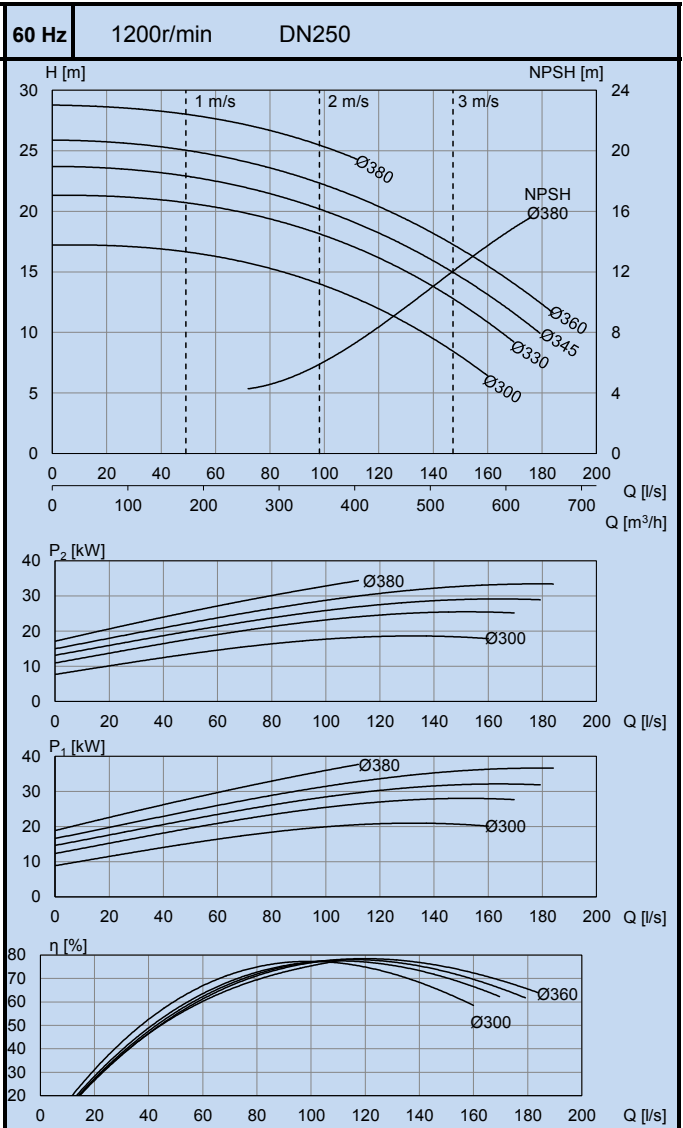
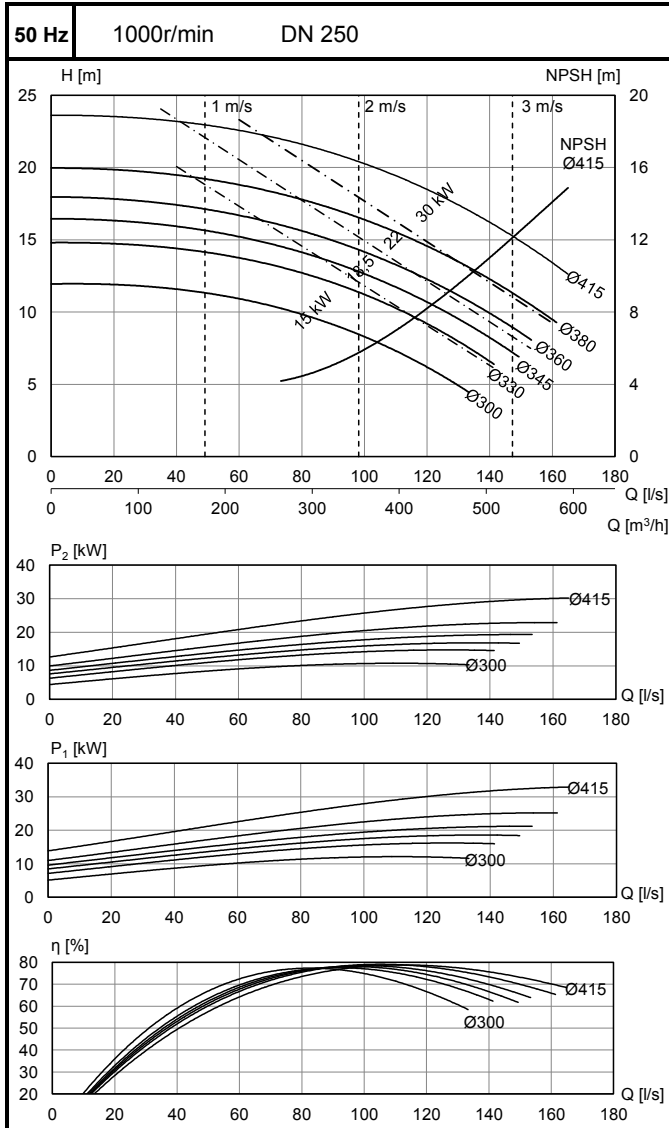



AL-1250/4 SD

ALH-1250/4 SD

ALS-1250/4 SD

P101352

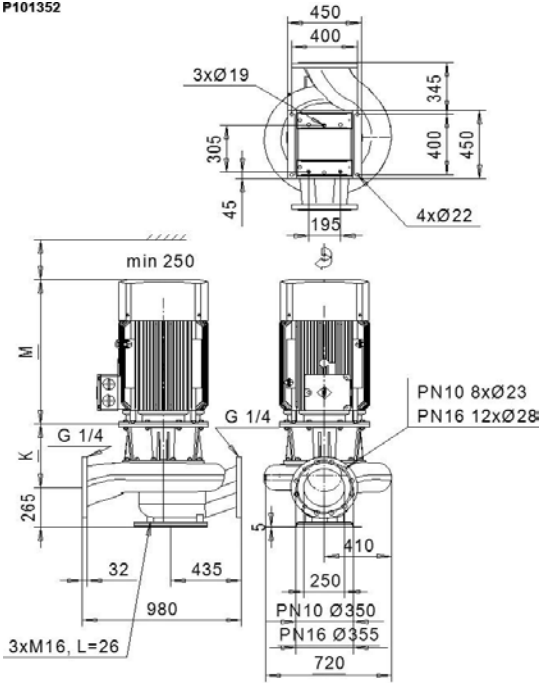

IEC-standard motor IM V1

|         | Motor 400V               | $P_{2N}$ [kW] | $I_N$ [A] ~ | [kg] ~ | M [mm] ~ | K [mm] ~ |
|---------|--------------------------|---------------|-------------|--------|----------|----------|
|         | ZH05                     | IEC-225       | 37          | 68     | 620      | 740      |
| IEC-225 |                          | 45            | 81          | 640    | 740      | 408      |
| IEC-250 |                          | 55            | 99          | 690    | 750      | 428      |
| IEC-280 |                          | 75            | 134         | 900    | 950      | 428      |
| IEC-280 |                          | 90            | 159         | 940    | 950      | 428      |
|         | Motor 380-400V(460-480V) | $P_{2N}$ [kW] | $I_N$ [A] ~ | [kg] ~ | M [mm] ~ | K [mm] ~ |
|         | IEC-225                  | 45 (54)       | 81          | 640    | 740      | 408      |
|         | IEC-250                  | 55 (66)       | 99          | 690    | 750      | 428      |
|         | IEC-280                  | 75 (90)       | 134         | 900    | 950      | 428      |
|         | IEC-280                  | 90 (105)      | 159         | 940    | 950      | 428      |

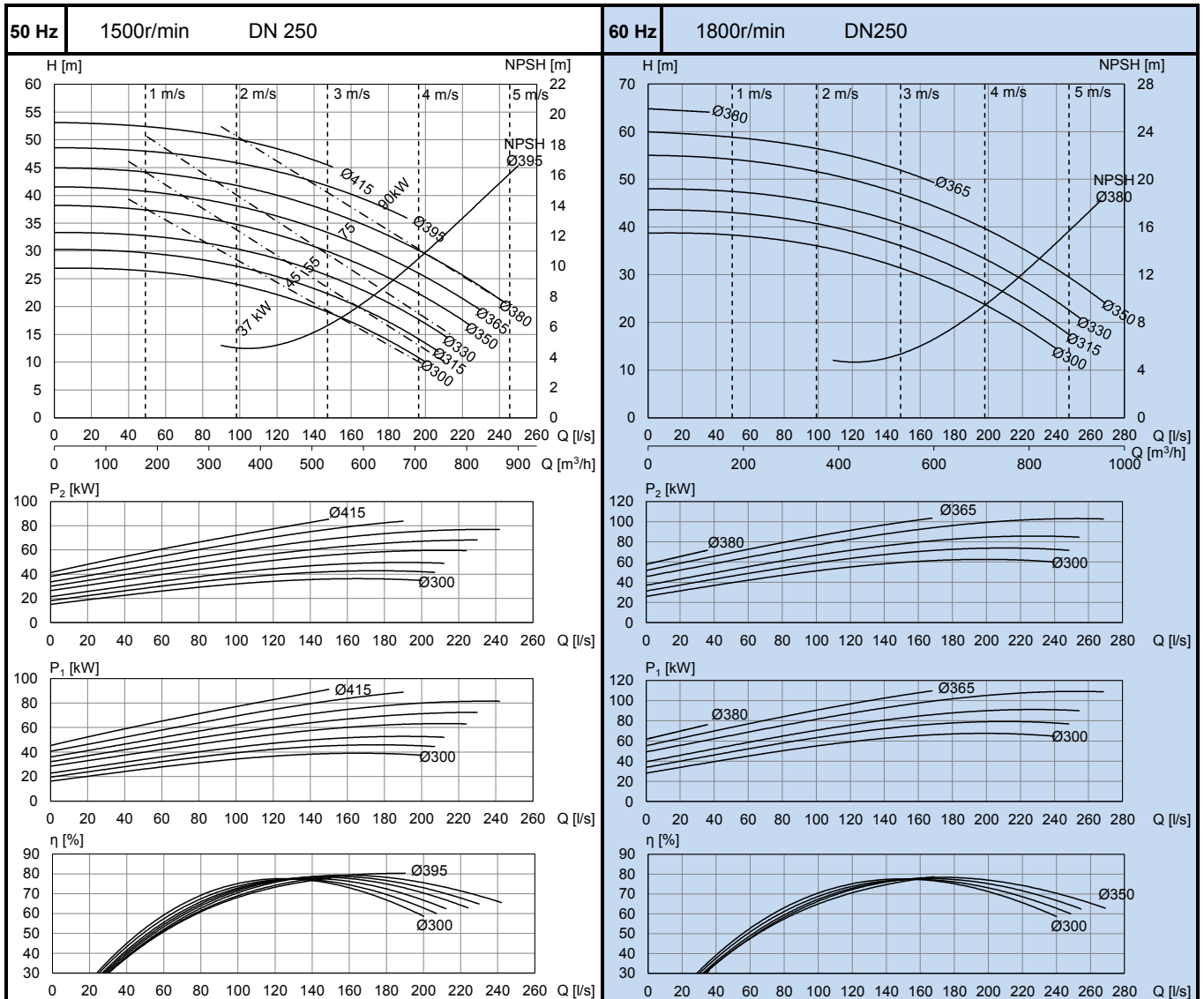









# KOLMEKS

EFFICIENT RELIABILITY

**KolmeKs Oy**

Taimistotie 2  
FI-14200 Turenki  
FINLAND

Phone. +358 20 7521 31  
Fax +358 20 7521 200

[kolmeKs@kolmeKs.fi](mailto:kolmeKs@kolmeKs.fi)  
[www.kolmeKs.fi/en](http://www.kolmeKs.fi/en)